

TRIGON XXL

---



# Contents

---

<b>Gas condensing boiler TRIGON XXL</b>	Models and output ..... 4 Application possibilities..... 4 Value propositions..... 4
<b>Technical description</b>	Technical description ..... 5 Technical data: TRIGON XXL SE ..... 6 Technical data: TRIGON XXL ECO ..... 8 Technical data: TRIGON XXL EVO..... 10 Dimensions..... 12 Declaration of conformity ..... 16 Extent of delivery: Standard boiler ..... 17 Boiler transport ..... 17 Boiler installation ..... 17 Component Dimensions..... 18
<b>Norms and regulations</b>	General regulations ..... 20 Application..... 20 Norms and regulations ..... 20 Additional national standards..... 20 Maintenance ..... 21 Fuel ..... 21 Combustion air ..... 21 Water quality ..... 21 Noise protection ..... 22 Antifreeze ..... 22
<b>Flue gas system</b>	Requirements and regulations ..... 23 Materials..... 23 Flue gas data..... 24 Dimensioning..... 25
<b>Neutralisation</b>	General ..... 26 Neutralisation systems..... 26 Standard neutralisation system (DN) ..... 26 Neutralisation system with pump (HN) ..... 26
<b>Hydraulic connection</b>	Hydraulic resistance ..... 27 $\Delta T$ -measurement..... 27 $\Delta p$ -measurement ..... 27 Water flow data: TRIGON XXL SE ..... 27 Water flow data: TRIGON XXL ECO ..... 28 Water flow data: TRIGON XXL EVO..... 29 Hydraulic connection into a system ..... 30 Standard..... 30 Bypass..... 30
<b>Controls</b>	Basic controls and connections..... 31 Control by building management system..... 31 Boiler enable signal ..... 31 Temperature or capacity setpoint ..... 31 Capacity feedback signal..... 32 OK/Alarm output signal..... 32 Heating zone control ..... 33 Cascade control ..... 33

# Contents

---

<b>Accessories</b>	System selection .....	34
	Accessories	
	2x max. Water pressure switch + 1x external high limit thermostat .....	35
	Max. gas pressure switch .....	35
	External high limit thermostat .....	35
	Gas valve leakage tester .....	35
	INAIL kit (Italy only) .....	35
	Plate heat exchanger + connection kit.....	36
	Low loss header + connection kit .....	37
	2x Bend 90° .....	39
	Flow adapter + NRV .....	39
	2nd return connection.....	39
	Safety valve (3-6 bar) + manometer .....	39
	Bypass.....	39
	Speed controlled pump.....	39
	Receiver wireless AVS71 .....	40
	Outdoor sensor wireless AVS13.....	40
	Room unit QAA75 .....	40
	Room unit QAA78 .....	40
	Cascade kit MASTER.....	40
	Cascade kit SLAVE .....	40
	LOGON B with wall hung box.....	40
	Wiring for room fan and external gas valve .....	40
	Header/hot water sensor QAZ36 .....	41
	Heating zone sensor QAD36.....	41
	Outdoor sensor QAC34.....	41
	Extension module AVS75.....	41
	Commercial Gateway .....	41
	Gas filter .....	42
	Gas pressure regulator 100mbar + connection kit.....	42
	Air filter .....	42
	Disassembly set .....	42
	Standard pumps .....	43
	Speed control pumps .....	44
	Bypass pumps.....	44
	Standard pumps performance curves .....	45
	Bypass pumps performance curves .....	46
	Speed control pumps performance curves .....	47
<b>Installation examples</b>	2-A-C: 1 heating zone + low loss header .....	48
	2-5-A-C: 1 heating zone and sanitary hot water + low loss header .....	59
	4-A-C: 2 heating zones + low loss header .....	50
	4-5-A-C: 2 heating zones and sanitary hot water + low loss header .....	51
	A-C: Boiler control via 0-10VDC + low loss header .....	52
	B-C: Boiler control via 0-10VDC + plate heat exchanger .....	53
	4-5-A-C-E: 2 heating zones and sanitary hot water + cascade via low loss header .....	54
	Extension 2 heating zones .....	55
<b>Technical Data</b>	Country specific.....	56
<b>Norms</b>	.....	64

# Gas condensing boiler TRIGON XXL

## Models and output Application possibilities Value propositions

---

### Models and output

The floor standing gas condensing boiler TRIGON XXL is available in 3 different ranges **SE**, **ECO** and **EVO**. **SE** is the low condensing series. It consists of 10 models covering an output range from 650 up to 1.900kW. The **ECO** series consists of 9 models and covers an output range of 650 up to 1.600kW with an excellent efficiency of 104,3%. The **EVO** series offers maximum output with the highest efficiency. 10 models cover an output range of 700 up to 2.000kW with an efficiency up to 109,8%.

### Application possibilities

The gas condensing boiler TRIGON XXL is applicable for alle central heating systems built according to EN12828. In cascade applications (max. 16 boilers with LMS14 master/slave cascade control) the TRIGON XXL can cover installations up to 32.000 kW . Preferred applications are central heating and sanitary hot water production in hospitals, municipal, sport facilities, hospitals, industrial and educational buildings.

### Value propositions

- Unique reliability proven technology with exceptional high quality
- Highest system flexibility easy planning and Plug & Play installation with pre-assembled system kits
- Easy maintenance boiler design optimised for easy access on servicing
- Unequalled lifetime high efficiency corrosion resistant stainless steel heat exchanger
- Environmental friendly lowest emission values
- The largest premix condensing boiler available on the market

The following table lists the different ranges and models of the TRIGON XXL

	TRIGON XXL		
Range	SE	ECO	EVO
Model	SE 650	ECO 650	EVO 700
	SE 750	ECO 750	EVO 800
	SE 850	ECO 850	EVO 900
	SE 1000	ECO 950	EVO 1000
	SE 1100	ECO 1050	EVO 1100
	SE 1200	ECO 1150	EVO 1200
	SE 1300	ECO 1300	EVO 1400
	SE 1500	ECO 1450	EVO 1550
	SE 1700	ECO 1600	EVO 1700
	SE 1900		EVO 2000

# Gas condensing boiler TRIGON XXL

## Technical description

### Technical Description

The TRIGON XXL is a fully modulating condensing boiler. The control unit of the boiler adapts the modulation ratio automatically to the heat demand requested by the system. This is done by controlling the speed of the fan. As a result, the whirlwind mixing system will adapt the gas ratio to the chosen fan speed, in order to maintain the best possible combustion figures and therefore with the best efficiency. The flue gases created by the combustion are transported downwards through the boiler and leave at the back side into the

chimney connection.

The return water from the system enters the boiler in the lower section, where is the lowest flue gas temperature in the boiler. In this section condensation takes place. The water is being transported upwards through the boiler, in order to leave the boiler at the top (burner) section. The cross flow working principle (water up, flue gas down) ensures the most efficient combustion results.

The LMS14 control unit can control the boiler operation based on:

- Boiler control (stand alone operation);
- weather compensated operation (with optional outdoor sensor);
- With 0-10V external influence (temperature or capacity) from a building management system.

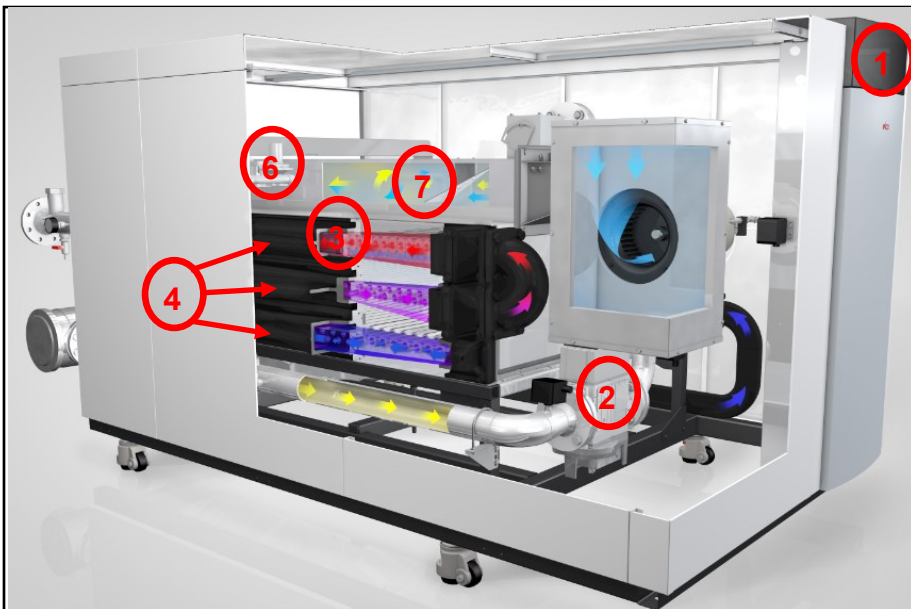

- 1 LMS14 boiler management unit (HMI)



- 2 Speed controlled Venturi gas/air mixing system  
 3 Water cooled premix burner  
 4 Water cooled stainless steel heat exchanger :  
 3 levels for SE and ECO versions  
 5 Water cooled stainless steel heat exchanger :  
 4 levels for EVO version  
 6 Pilot mixing system  
 7 Main mixing system

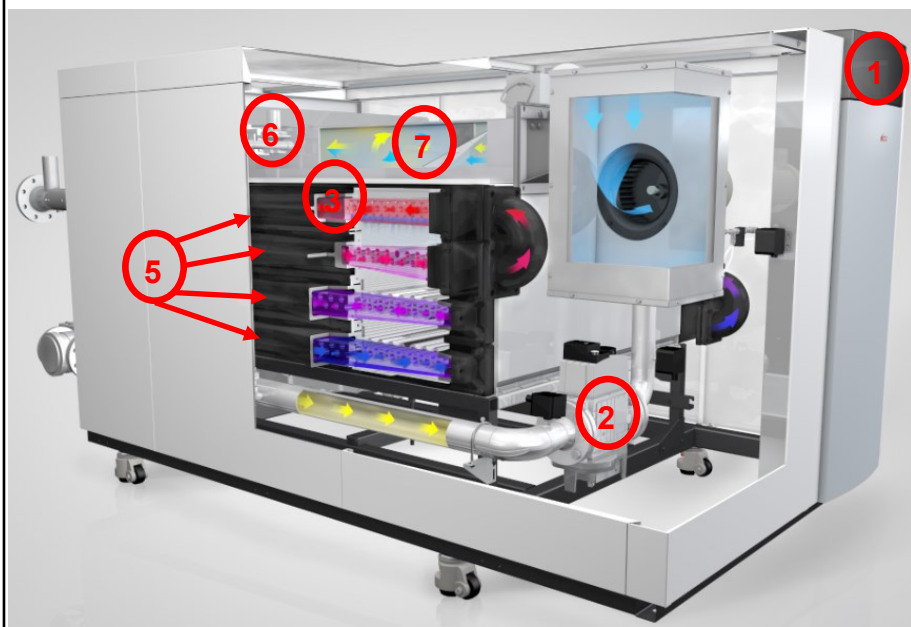

# Technical description

## Technical data

		TRIGON XXLSE				
		650	750	850	1000	1100
Nominal heat output at 80/60°C max/min	kW	650/164	726/183	849/213	961/242	1073/270
Nominal heat output at 40/30°C max/min	kW	657/183	733/204	858/238	971/270	1084/301
Nominal heat input Hi max/min	kW	702/176	784/196	917/229	1038/260	1159/290
Efficiency at 80/60°C	%	93,2				
Efficiency at 40/30°C	%	103,9				
RAL 40/30 average	%	103,3				
Max. condensate flow	l/h	3,2	3,6	4,2	4,8	5,3
Gas consumption G20 max/min (10,9 kWh/m <sup>3</sup> )	m <sup>3</sup> /h	64,4/16,1	71,9/18,0	84,1/21,0	95,2/23,9	106,3/26,6
Gas consumption G25 max/min (8,34 kWh/m <sup>3</sup> )	m <sup>3</sup> /h	84,2/21,1	94,0/23,5	110,0/27,5	124,5/31,2	139,0/34,8
Gas consumption G31 max/min (12,8 kWh/kg)	kg/h	54,87/13,8	61,3/15,3	71,6/17,9	81,1/20,3	90,5/22,7
Gas pressure H-gas	mbar	20		35		
Gas pressure L-gas	mbar	25		35		
Gas pressure LPG	mbar	30		50		
Maximum gas pressure	mbar	100				
Flue gas temperature at 80/60°C max/min	°C	182/66				
Flue gas temperature at 40/30°C max/min	°C	167/65				
Flue gas quantity max/min	m <sup>3</sup> /h	1438/286	1606/318	1878/372	2126/422	2374/471
CO2 level G20-G25 max/min	%	10,0/10,2				
CO2 level G31 max/min	%	11,0/11,2				
NOx level at 80/60 °C max/min	mg/kWh	45/23				
CO level at 80/60 °C max/min	mg/kWh	7/3				
Max. permissible flue resistance	Pa	150				
Water volume	l	50	53	70	75	80
Water pressure max/min	bar	8/1,5				
Max. water temperature (High limit thermostat)	°C	100				
Maximum temperature setpoint	°C	90				
Nominal water flow at dT=20K	m <sup>3</sup> /h	28	31	36	41	46,0
Hydraulic resistance at nominal flow rate	kPa	46	53	36	43	50
Electrical connection	V	400				
Frequency	Hz	50				
Mains connection fuse	A	16				
IP class	-	IP00				
Electrical consumption boiler max/min (without pump)	W	900/225		1270/320		
Weight (empty)	kg	770	844	958	1084	1221
Sound Power Level (LWA)	dB	72,7				
Ionisation current min	µA	0,52				
PH value condensate	-	3,2				
CE certification code	-	CE 0063CR3158				
Water connections	-	DN65 PN16		DN80 PN16		
Gas connection	-	DN50			DN65 PN16	
Flue gas connection (DN)	mm	300	350		400	
Air intake connect. (room sealed use) (DN)	mm	250	355			
Condensate connection	mm	40				

# Technical description

## Technical data

		TRIGON XXL SE				
		1200	1300	1500	1700	1900
Nominal heat output at 80/60°C max/min	kW	1184/298	1296/326	1481/373	1666/419	1851/466
Nominal heat output at 40/30°C max/min	kW	1196/332	1309/363	1496/415	1684/467	1871/519
Nominal heat input Hi max/min	kW	1279/320	1400/350	1600/400	1800/450	2000/500
Efficiency at 80/60°C	%	93,2				
Efficiency at 40/30°C	%	103,9				
RAL 40/30 average	%	103,3				
Max. condensate flow	l/h	5,9	6,4	7,4	8,3	9,2
Gas consumption G20 max/min (10,9 kWh/m <sup>3</sup> )	m <sup>3</sup> /h	117,3/29,4	128,4/32,1	146,7/36,7	165,1/41,3	183,5/45,9
Gas consumption G25 max/min (8,34 kWh/m <sup>3</sup> )	m <sup>3</sup> /h	153,4/38,4	167,9/42,0	191,8/48,0	215,8/54,0	239,8/60,0
Gas consumption G31 max/min (12,8 kWh/kg)	kg/h	99,9/25,0	109,4/27,3	125/31,3	140,6/35,2	156,3/39,1
Gas pressure H-gas	mbar	35	50			
Gas pressure L-gas	mbar	35	50			
Gas pressure LPG	mbar	50				
Maximum gas pressure	mbar	100				
Flue gas temperature at 80/60°C max/min	°C	182/66				
Flue gas temperature at 40/30°C max/min	°C	167/65				
Flue gas quantity max/min	m <sup>3</sup> /h	2619/519	2867/568	3277/649	3685/730	4095/811
CO <sub>2</sub> level G20-G25 max/min	%	10,0/10,2				
CO <sub>2</sub> level G31 max/min	%	11,0/11,2				
NO <sub>x</sub> level at 80/60 °C max/min	mg/kWh	45/23				
CO level at 80/60 °C max/min	mg/kWh	7/3				
Max. permissible flue resistance	Pa	150				
Water volume	l	85	97	109	116	123
Water pressure max/min	bar	8/1,5				
Max. water temperature (High limit thermostat)	°C	100				
Maximum temperature setpoint	°C	90				
Nominal water flow at dT=20K	m <sup>3</sup> /h	50,9	55,7	63,7	71,6	79,6
Hydraulic resistance at nominal flow rate	kPa	58	91	60	130	165
Electrical connection	V	400				
Frequency	Hz	50				
Mains connection fuse	A	16				
IP class	-	IP00				
Electrical consumption boiler max/min (without pump)	W	1270/320	2330/585		2770/695	
Weight (empty)	kg	1369	1380	1740	1899	1991
Sound Power Level (LWA)	dB	72,7				
Ionisation current max/min	µA	0,52				
PH value condensate	-	3,2				
CE certification code	-	CE 0063CR3158				
Water connections	-	DN80 PN16				
Gas connection	-	DN65 PN16			DN80 PN16	
Flue gas connection (DN)	mm	450			500	
Air intake connect. (room sealed use) (DN)	mm	355	450			
Condensate connection	mm	40				

# Technical description

## Technical data

		TRIGON XXL ECO				
		650	750	850	950	1050
Nominal heat output at 80/60°C max/min	kW	615/175	719/204	814/231	909/258	1003/285
Nominal heat output at 40/30°C max/min	kW	625/195	732/227	828/257	925/287	1021/318
Nominal heat input Hi max/min	kW	653/187	764/218	865/247	966/276	1066/305
Efficiency at 80/60°C	%	94,1				
Efficiency at 40/30°C	%	104,1				
RAL 40/30 average	%	103,7				
Max. condensate flow	l/h	7,8	9,1	10,3	11,5	12,7
Gas consumption G20 max/min (10,9 kWh/m <sup>3</sup> )	m <sup>3</sup> /h	59,9/17,2	70,1/20	79,4/22,7	88,6/25,3	97,8/28
Gas consumption G25 max/min (8,34 kWh/m <sup>3</sup> )	m <sup>3</sup> /h	78,3/22,4	91,6/26,1	103,7/29,6	115,8/33,1	127,8/36,5
Gas consumption G31 max/min (12,8 kWh/kg)	kg/h	51,0/14,6	59,7/17	67,6/19,3	75,5/21,6	83,3/23,8
Gas pressure H-gas	mbar	20				
Gas pressure L-gas	mbar	25				
Gas pressure LPG	mbar	30				
Maximum gas pressure	mbar	100				
Flue gas temperature at 80/60°C max/min	°C	153/65				
Flue gas temperature at 40/30°C max/min	°C	134/64				
Flue gas quantity max/min	m <sup>3</sup> /h	1252/303	1465/353	1659/400	1852/447	2044/493
CO2 level G20-G25 max/min	%	10,0/10,2				
CO2 level G31 max/min	%	11,0/11,2				
NOx level at 80/60 °C max/min	mg/kWh	37/22				
CO level at 80/60 °C max/min	mg/kWh	4/3				
Max. permissible flue resistance	Pa	150				
Water volume	l	53	70	75	80	85
Water pressure max/min	bar	8/1,5				
Max. water temperature (High limit thermostat)	°C	100				
Maximum temperature setpoint	°C	90				
Nominal water flow at dT=20K	m <sup>3</sup> /h	26	31	35	39	43
Hydraulic resistance at nominal flow rate	kPa	37	25	30	35	40
Electrical connection	V	400				
Frequency	Hz	50				
Mains connection fuse	A	16				
IP class	-	IP00				
Electrical consumption boiler max/min (without pump)	W	900/225		1270/320		
Weight (empty)	kg	844	958	1084	1221	1369
Sound Power Level (LWA)	dB	68,7				
Ionisation current max/min	µA	0,52				
PH value condensate	-	3,2				
CE certification code	-	CE 0063CR3158				
Water connections	-	DN65 PN16	DN80 PN16			
Gas connection	-	DN50			DN65 PN16	
Flue gas connection (DN)	mm	350			400	
Air intake connect, (room sealed use) (DN)	mm	355				
Condensate connection	mm	40				

# Technical description

## Technical data TRIGON XXL-ECO

		TRIGON XXL ECO			
		1150	1300	1450	1600
Nominal heat output at 80/60°C max/min	kW	1097/311	1255/356	1411/400	1568/445
Nominal heat output at 40/30°C max/min	kW	1117/347	1277/397	1436/446	1596/496
Nominal heat input Hi max/min	kW	1166/333	1333/381	1449/428	1666/476
Efficiency at 80/60°C	%	94,1			
Efficiency at 40/30°C	%	104,1			
RAL 40/30 average	%	103,7			
Max. condensate flow	l/h	13,9	15,9	17,9	19,9
Gas consumption G20 max/min (10,9 kWh/m <sup>3</sup> )	m <sup>3</sup> /h	107/30,6	122,3/35	137,5/39,3	152,8/43,7
Gas consumption G25 max/min (8,34 kWh/m <sup>3</sup> )	m <sup>3</sup> /h	139,8/39,9	159,8/45,7	179,7/51,3	199,8/57,1
Gas consumption G31 max/min (12,8 kWh/kg)	kg/h	91,1/26	104,1/29,8	117,1/33,4	130,2/37,2
Gas pressure H-gas	mbar	35			
Gas pressure L-gas	mbar	35			
Gas pressure LPG	mbar	50			
Maximum gas pressure	mbar	100			
Flue gas temperature at 80/60°C max/min	°C	153/65			
Flue gas temperature at 40/30°C max/min	°C	134/64			
Flue gas quantity max/min	m <sup>3</sup> /h	2236/576	2556/616	2874/692	3194/770
CO2 level G20-G25 max/min	%	10,0/10,2			
CO2 level G31 max/min	%	11,0/11,2			
NOx level at 80/60 °C max/min	mg/kWh	37/22			
CO level at 80/60 °C max/min	mg/kWh	4/3			
Max. permissible flue resistance	Pa	150			
Water volume	l	97	109	116	123
Water pressure max/min	bar	8/1,5			
Max. water temperature (High limit thermostat)	°C	100			
Maximum temperature setpoint	°C	90			
Nominal water flow at dT=20K	m <sup>3</sup> /h	47	54	60,7	67,4
Hydraulic resistance at nominal flow rate	kPa	60	72	93	114
Electrical connection	V	400			
Frequency	Hz	50			
Mains connection fuse	A	16			
IP class	-	IP00			
Electrical consumption boiler max/min (without pump)	W	2330/585		2770/695	
Weight (empty)	kg	1380	1740	1899	1991
Sound Power Level (LWA)	dB	68,7			
Ionisation current min	µA	0,52			
PH value condensate	-	3,2			
CE certification code	-	CE 0063CR3158			
Water connections	-	DN80PN16			
Gas connection	-	DN65PN16		DN80PN16	
Flue gas connection (DN)	mm	450		500	
Air intake connect. (room sealed use) (DN)	mm	450			
Condensate connection	mm	40			

# Technical description

## Technical data TRIGON XXL-EVO

		TRIGON XXL EVO				
		700	800	900	1000	1100
Nominal heat output at 80/60°C max/min	kW	639/182	747/212	846/241	945/269	1043/297
Nominal heat output at 40/30°C max/min	kW	682/205	798/239	904/271	1009/303	1114/334
Nominal heat input Hi max/min	kW	653/187	764/218	865/247	966/276	1066/305
Efficiency at 80/60°C	%	97,8				
Efficiency at 40/30°C	%	109,4				
RAL 40/30 average	%	108,4				
Max. condensate flow	l/h	42,4	49,6	56,1	62,7	69,1
Gas consumption G20 max/min (10,9 kWh/m <sup>3</sup> )	m <sup>3</sup> /h	59,9/17,2	70,1/20,0	79,4/22,7	88,6/25,3	97,8/28
Gas consumption G25 max/min (8,34 kWh/m <sup>3</sup> )	m <sup>3</sup> /h	78,3/22,4	91,6/26,1	103,7/29,6	115,8/33,1	127,8/36,6
Gas consumption G31 max/min (12,8 kWh/kg)	kg/h	51,0/14,6	59,7/17,0	67,6/19,3	75,5/21,6	83,3/23,8
Gas pressure H-gas	mbar	20				
Gas pressure L-gas	mbar	25				
Gas pressure LPG	mbar	30				
Maximum gas pressure	mbar	100				
Flue gas temperature at 80/60°C max/min	°C	69/59				
Flue gas temperature at 40/30°C max/min	°C	51/32				
Flue gas quantity max/min	m <sup>3</sup> /h	1005/297	1176/346	1332/393	1487/439	1641/485
CO2 level G20-G25 max/min	%	10,0/10,2				
CO2 level G31 max/min	%	11,0/11,2				
NOx level at 80/60 °C max/min	mg/kWh	37/22				
CO level at 80/60 °C max/min	mg/kWh	4/2				
Max. permissible flue resistance	Pa	150				
Water volume	l	73	97	104	110	117
Water pressure max/min	bar	8/1.5				
Max. water temperature (High limit thermostat)	°C	100				
Maximum temperature setpoint	°C	90				
Nominal water flow at dT=20K	m <sup>3</sup> /h	27	32	36	41	45
Hydraulic resistance at nominal flow rate	kPa	74	40	45	67	78
Electrical connection	V	400				
Frequency	Hz	50				
Mains connection fuse	A	16				
IP class	-	IP00B				
Electrical consumption boiler max/min (without pump)	W	900/225		1270/320		
Weight (empty)	kg	1136	1328	1468	1634	1800
Sound Power Level (LWA)	dB	68,7				
Ionisation current max/min	µA	0,52				
PH value condensate	-	3,2				
CE certification code	-	0063CR3158				
Water connections	-	DN65 PN16	DN80 PN16			
Gas connection	-	DN50			DN65 PN16	
Flue gas connection (DN)	mm	300	350		400	
Air intake connect. (room sealed use) (DN)	mm	250	355			
Condensate connection	mm	40				

# Technical description

## Technical data TRIGON XXL-EVO

		TRIGON XXL EVO				
		1200	1400	1550	1700	2000
Nominal heat output at 80/60°C max/min	kW	1141/324	1304/371	1467/417	1562/464	1953/487
Nominal heat output at 40/30°C max/min	kW	1218/365	1393/418	1566/469	1741/522	2087/548
Nominal heat input Hi max/min	kW	1166/333	1333/381	1449/428	1666/476	2000/500
Efficiency at 80/60°C	%	97,8				97,6
Efficiency at 40/30°C	%	109,7				
RAL 40/30 average	%	108,4				
Max. condensate flow	l/h	75,6	86,5	97,2	108,1	75,5
Gas consumption G20 max/min (10,9 kWh/m <sup>3</sup> )	m <sup>3</sup> /h	107/30,6	122,3/35,0	137,5/39,3	152,8/43,7	183,5/52,4
Gas consumption G25 max/min (8,34 kWh/m <sup>3</sup> )	m <sup>3</sup> /h	139,8/39,9	159,8/45,7	179,7/51,3	199,8/57,1	293,8/68,5
Gas consumption G31 max/min (12,8 kWh/kg)	kg/h	91,1/26,0	104,1/29,8	117/33,4	130,2/37,2	156,3/44,6
Gas pressure H-gas	mbar	35				50
Gas pressure L-gas	mbar	35				50
Gas pressure LPG	mbar	50				
Maximum gas pressure	mbar	100				
Flue gas temperature at 80/60°C max/min	°C	69/59				73/59
Flue gas temperature at 40/30°C max/min	°C	51/32				
Flue gas quantity max/min	m <sup>3</sup> /h	1795/529	2052/605	2307/680	2565/756	
CO2 level G20-G25 max/min	%	10.0/10.2				
CO2 level G31 max/min	%	11.0/11.2				
NOx level at 80/60 °C max/min	mg/kWh	37/22				32/23
CO level at 80/60 °C max/min	mg/kWh	4/2				
Max. permissible flue resistance	Pa	150				
Water volume	l	131	147,2	156,6	166,1	209,0
Water pressure max/min	bar	8/1,5				
Max. water temperature (High limit thermostat)	°C	100				
Maximum temperature setpoint	°C	90				
Nominal water flow at dT=20K	m <sup>3</sup> /h	49,0	56,1	63,1	70,1	84,0
Hydraulic resistance at nominal flow rate	kPa	82	96	136	162	216
Electrical connection	V	400				
Frequency	Hz	50				
Mains connection fuse	A	16				
IP class	-	IP00				
Electrical consumption boiler max/min (without pump)	W	2330/585		2770/695		
Weight (empty)	kg	1900	2000	2100	2201	2500
Sound Power Level (LWA)	dB	68,7				72,7
Ionisation current max	µA	0.52				
PH value condensate	-	3,2				
CE certification code	-	CE 0063CR3158				
Water connections	-	DN80PN16				
Gas connection	-	DN65 PN16		DN80PN16		
Flue gas connection (DN)	mm	450		500		
Air intake connect. (room sealed use) (DN)	mm	450				
Condensate connection	mm	40				

# Technical description

## Dimensions TRIGON XXL SE/ECO/EVO

Dimensions		SE 650	SE 750	SE 850	SE 1000	SE 1100	SE 1200	EVO 700	EVO 800	EVO 900	EVO 1000	EVO 1100
		ECO 650	ECO 750	ECO 850	ECO 950	ECO 1050						
L	mm	2185	2185	2565	2565	2565	2565	2185	2565	2565	2565	2565
L1	mm	475	475	480	480	480	480	475	480	480	480	480
L2	mm	660	660	1030	1030	1030	1030	660	1030	1030	1030	1030
L3	mm	210	260	260	260	260	260	260	260	260	260	260
L4	mm	110	110	110	110	110	110	110	110	110	100	100
L5	mm	420	550	550	550	550	550	550	550	550	550	550
LW	mm	185	185	185	185	185	185	185	185	185	185	185
H	mm	1555	1555	1555	1555	1555	1555	1555	1555	1555	1555	1555
H1	mm	960	960	960	960	960	960	1110	1110	1110	1110	1110
H2	mm	660	660	660	660	660	660	660	660	660	660	660
H3	mm	540	530	530	530	530	530	530	530	530	530	530
H4	mm	480	480	500	500	500	500	460	460	480	480	480

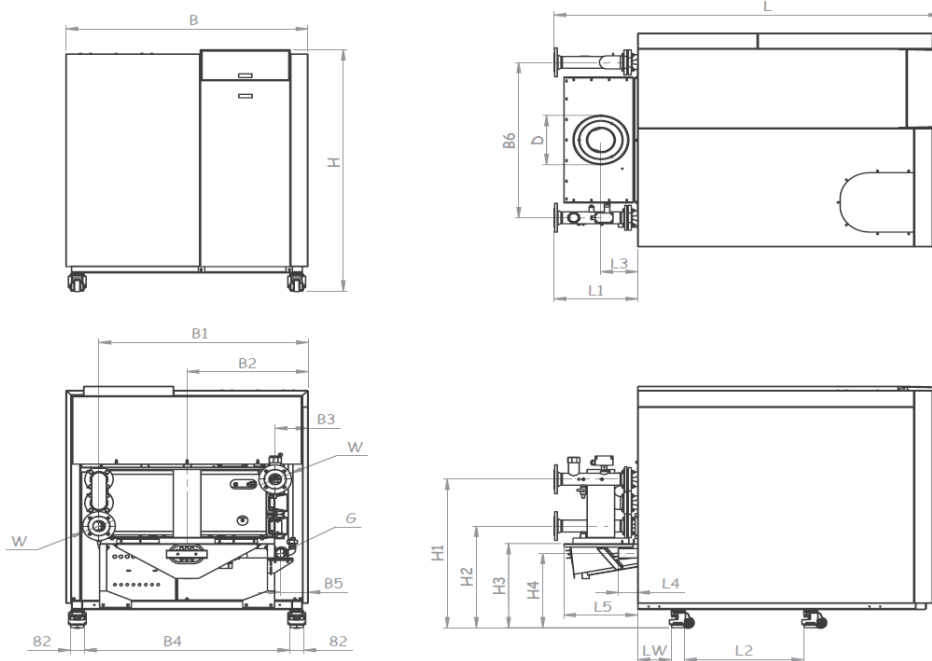

Dimensions		SE 650	SE 750	SE 850	SE 1000	SE 1100	SE 1200	EVO 700	EVO 800	EVO 900	EVO 1000	EVO 1100
		ECO 650	ECO 750	ECO 850	ECO 950	ECO 1050						
B	mm	1370	1370	1170	1170	1370	1370	1370	1170	1170	1370	1370
B1	mm	1185	1235	1025	1075	1225	1275	1235	1025	1075	1225	1275
B2	mm	685	685	585	585	685	685	685	585	585	685	685
B3	mm	185	135	145	95	145	95	135	145	95	145	95
B4	mm	1160	1160	960	960	1160	1160	1160	960	960	1160	1160
B5	mm	150	100	150	100	150	100	100	150	100	150	100
B6	mm	1000	1100	880	980	1080	1180	1100	880	980	1080	1180
D	mm	300	350	350	400	400	400	300	350	350	400	400
W	DN	DN65PN16	DN65PN16	DN80PN16	DN80PN16	DN80PN16	DN80PN16	DN65PN16	DN80PN16	DN80PN16	DN80PN16	DN80PN16
G	DN	DN50	DN50	DN50	DN50	DN65PN16	DN65PN16	DN50	DN50	DN50	DN65PN16	DN65PN16

# Technical description

## Dimensions TRIGON XXL SE/ECO

Dimensions		SE 1300	SE 1500
		ECO 1150	ECO 1300
L	mm	2795	3310
L1	mm	480	480
L2	mm	1030	1550
L3	mm	350	350
L4	mm	230	230
L5	mm	710	710
LW	mm	185	185
H	mm	1555	1575
H1	mm	895	915
H2	mm	420	435
H3	mm	470	490
H4	mm	240	260

Dimensions		SE 1300	SE 1500
		ECO 1150	ECO 1300
B	mm	1570	1370
B1	mm	1445	1250
B2	mm	785	685
B3	mm	145	145
B4	mm	1360	1160
B5	mm	145	145
B6	mm	1300	1105
D	mm	450	450
W	DN	DN80-PN16	DN80-PN16
G	DN	DN65-PN16	DN65-PN16

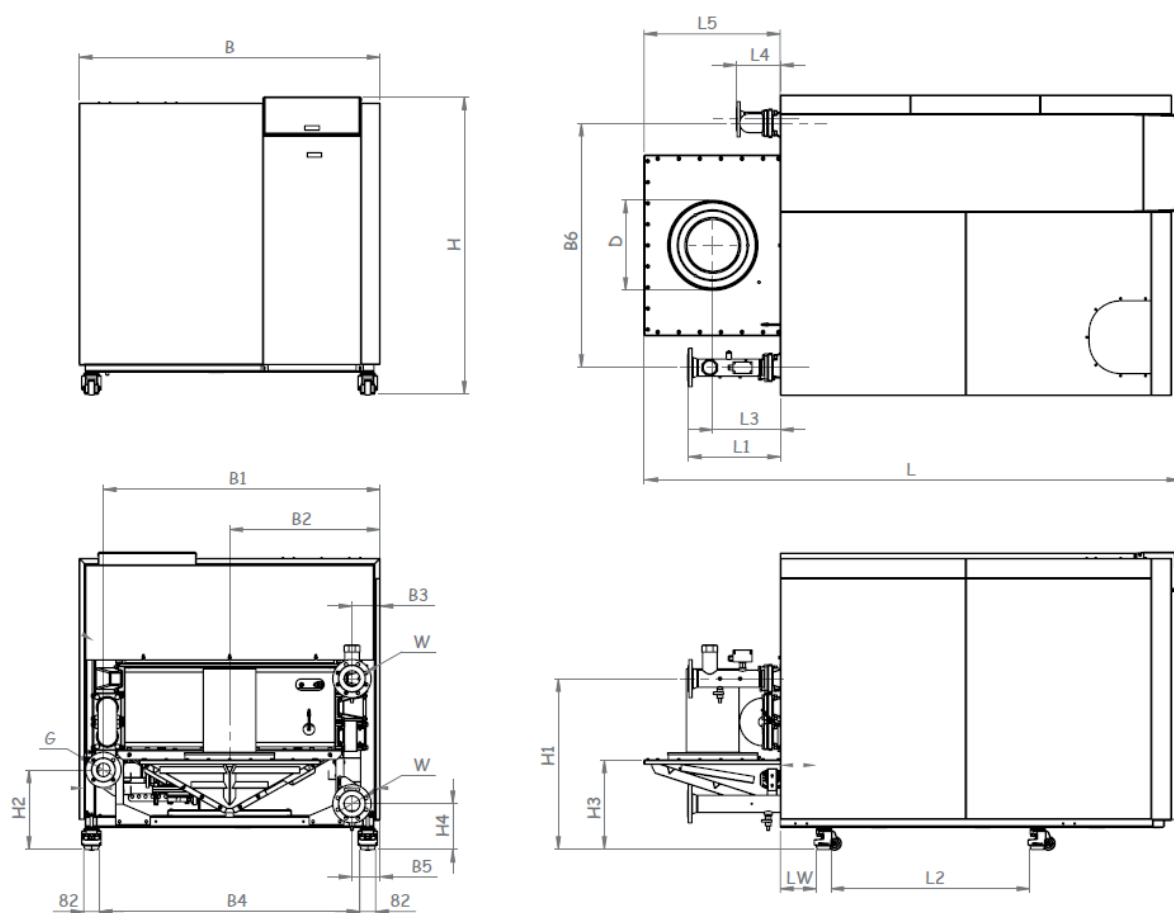

# Technical description

## Dimensions TRIGON XXL SE/ECO/EVO

Dimensions		SE 1700	SE 1900
		ECO 1450	ECO 1600
L	mm	3310	3310
L1	mm	480	480
L2	mm	1550	1550
L3	mm	350	350
L4	mm	150	150
L5	mm	710	710
LW	mm	185	185
H	mm	1575	1575
H1	mm	915	915
H2	mm	440	440
H3	mm	490	490
H4	mm	260	260

Dimensions		SE 1300	SE 1500
		ECO 1150	ECO 1300
B	mm	1570	1570
B1	mm	190	140
B2	mm	785	785
B3	mm	195	145
B4	mm	1360	1360
B5	mm	1375	1425
B6	mm	1180	1280
D	mm	500	500
W	DN	DN80-PN16	DN80-PN16
G	DN	DN80-PN16	DN80-PN16

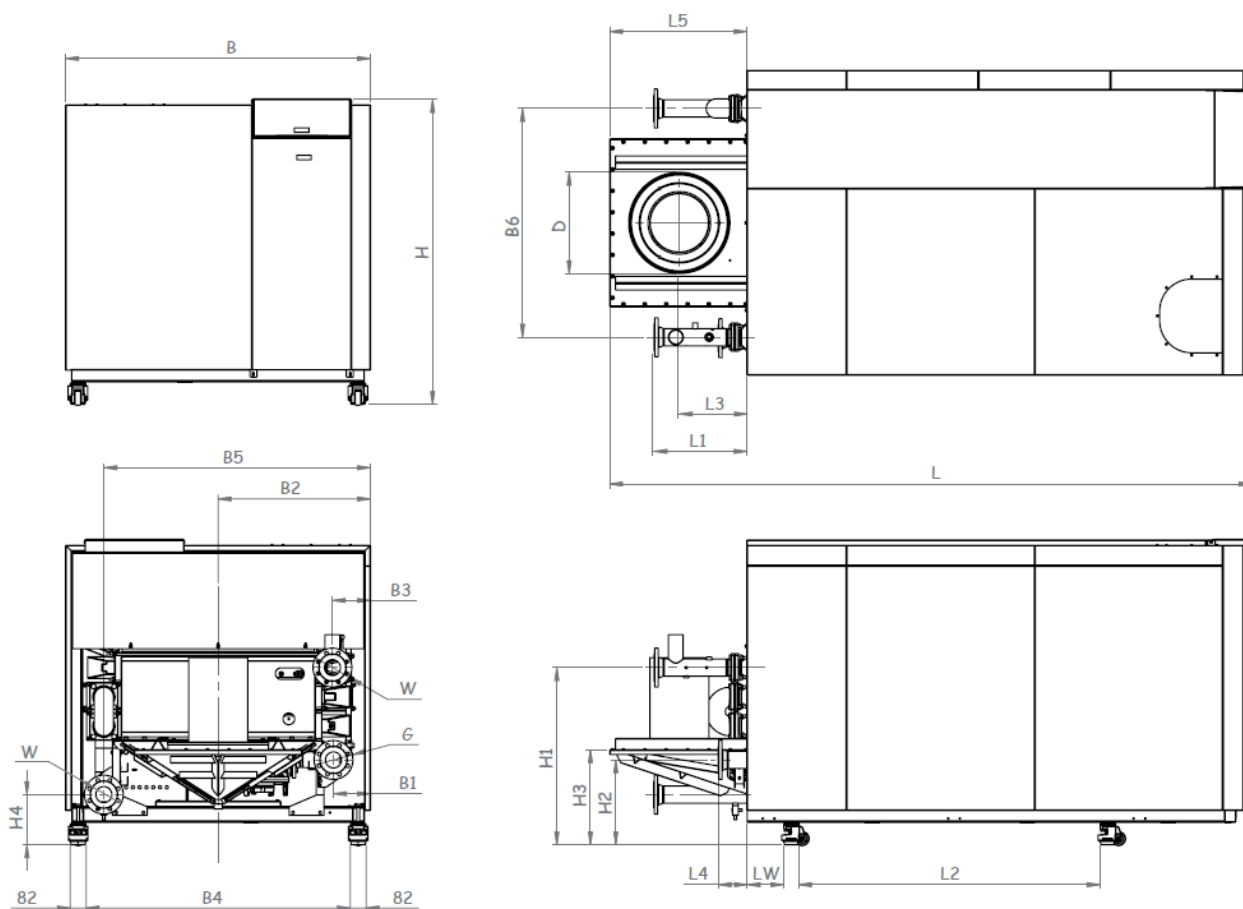

# Technical description

## Dimensions TRIGON XXL SE/ECO

Dimensions		EVO 1200	EVO 1400	EVO 1550	EVO 1700	EVO 2000
L	mm	2795	3310	3310	3310	3310
L1	mm	480	480	480	480	480
L2	mm	1030	1550	1550	1550	1550
L3	mm	350	350	350	350	350
L4	mm	230	165	150	150	165
L5	mm	710	710	710	710	710
LW	mm	185	185	185	185	185
H	mm	1555	1575	1575	1575	1665
H1	mm	1045	1065	1065	1065	1225
H2	mm	395	415	435	435	435
H3	mm	470	490	490	490	505
H4	mm	595	615	615	615	395

Dimensions		EVO 1200	EVO 1400	EVO 1550	EVO 1700	EVO 2000
B	mm	1570	1370	1570	1570	1570
B1	mm	150	140	190	140	140
B2	mm	785	685	785	785	785
B3	mm	145	145	195	145	145
B4	mm	1360	1160	1360	1360	1145
B5	mm	1425	1225	1375	1425	1425
B6	mm	1280	1080	1180	1280	1280
D	mm	450	450	500	500	500
W	DN	DN80	DN80	DN80	DN80	DN80
G	DN	DN65	DN65	DN80	DN80	DN80

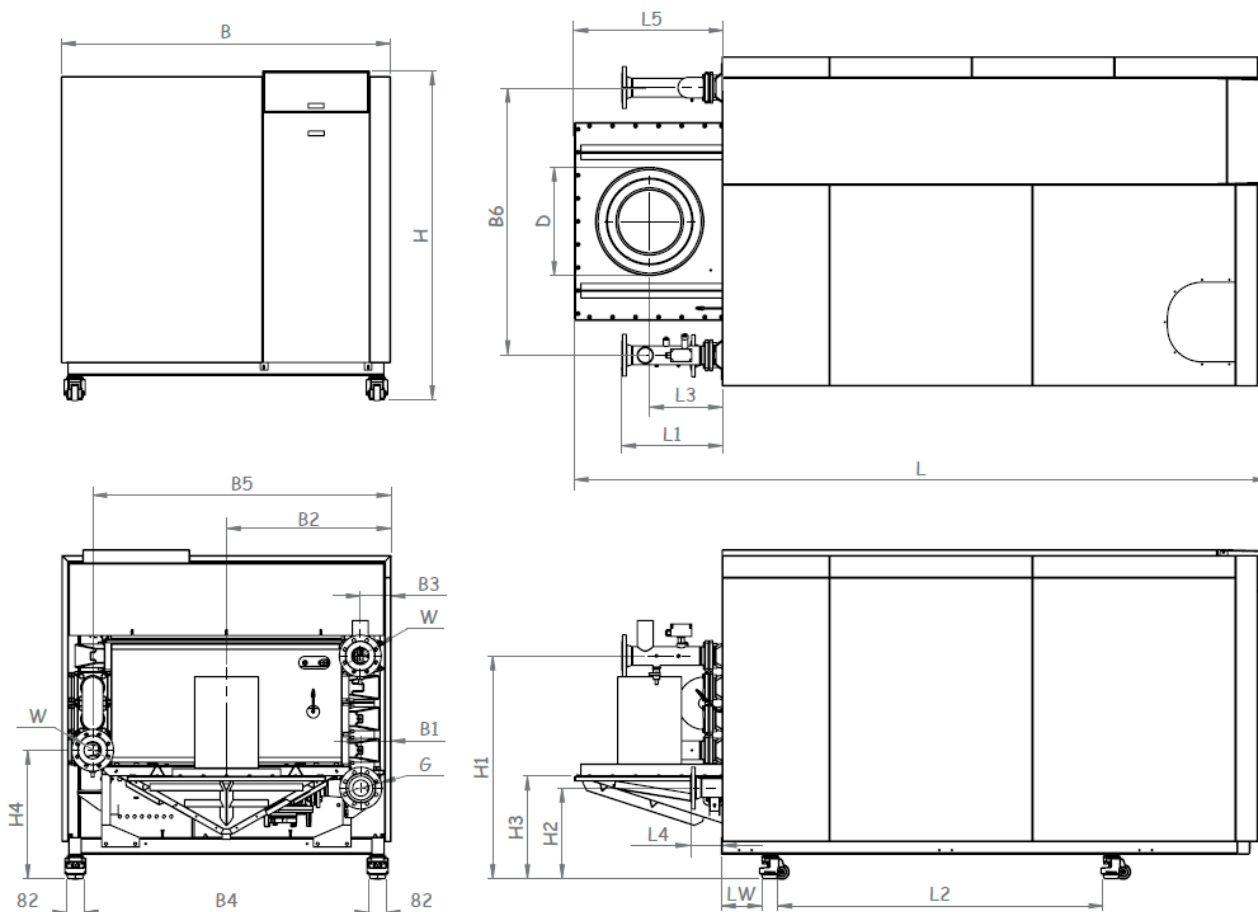

## Technical description

### Declaration of conformity

## Declaration of Conformity

ELCO BV, Hamstraat 76, 6465 AG Kerkrade (NL),  
Declares that the product

## TRIGON XXL

Is in conformity with the following standards:

EN 15502-1  
EN 15502-2-1  
EN 55014-1 / -2  
EN 61000-3-2 /-3  
EN 60 335-1/ -2

And in accordance with the guidelines of directives:

92 / 42 / EEC (boiler efficiency directive)  
2009 / 142 / EEC (gas appliance directive)  
2014 / 35 / EU (low voltage directive)  
2014 / 30 / EU (EMC directive)  
2009 / 125 / CE Energy related Products  
811-813-814 / 2013 EU regulation

This product is designated with CE number:

**CE-0063CR3158**

Kerkrade, 30-09-2017

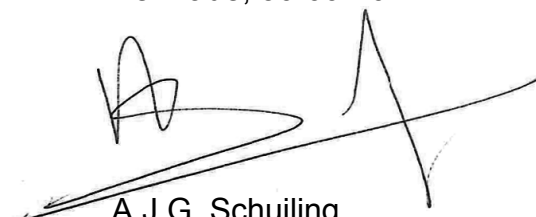

A.J.G. Schuiling  
Plant Manager

# Extent of delivery

## Standard boiler Boiler transport Boiler installation

### Standard boiler

A boiler delivery package contains the following components:

Component	Pcs.	Package
Boiler fully assembled and tested	1	On wooden pallet, sealed in PE foil
Syphon + dirt separator for condensate connection	1	Cardboard box on top of heat exchanger (under casing)
Operation and Installation manual	1	On inside of front panel

### Boiler transport

Whenever necessary, the boiler can be dismantled into smaller parts for easier transport inside the building. The table below shows the main dismantled parts with their weight and dimensions.

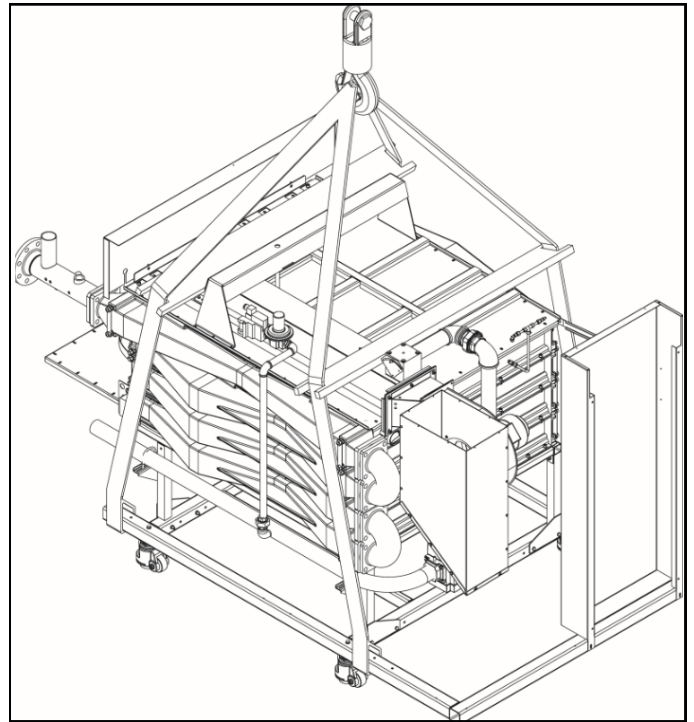

### Boiler installation

The boiler should be positioned in a frost-proof boiler room. If the boiler room is on the roof, the boiler itself may never be the highest point of the installation.

When positioning the boiler, please note the recommended minimum clearance in the picture. When the boiler is positioned with less free space, maintenance activities will be more difficult.

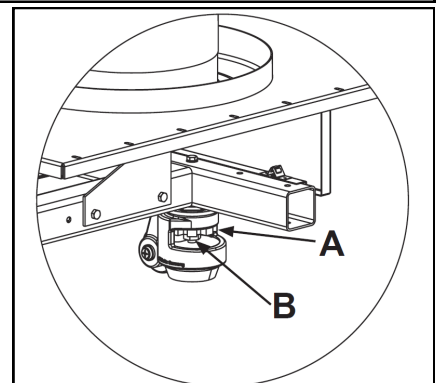
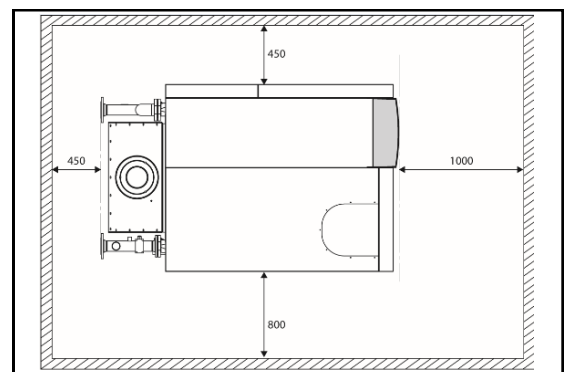

Once the boiler is in the correct position, turn anti-clockwise the regulator (A) or the nut (B) to let the feet out, till the boiler is set in the right height.. Ensure that the wheels are not in contact with the floor!

Water and gas connections should be done after adjusting the feet, as they affect the exact height of all connections.

The (inter)national and local norms for the installation of heating systems should be respected at all times.

# Extent of delivery

## Component Dimensions:Trigon XXL SE/ECO/EVO

Component		SE-650	SE-750	SE-850	SE-1000	SE-1100	SE-1200	EVO-700	EVO-800	EVO-900	EVO-1000	EVO-1100
		ECO-650	ECO-750	ECO-850	ECO-950	ECO-1050						
Burner	m [kg]	135										225
	L [mm]	1110	1110	1587	1587	1478	1585	1114	1585	1590	1590	1590
	B [mm]	1257	1257	1025	1125	1225	1425	1135	995	1095	1209	1295
	H [mm]	416	416	416	416	416	416	416	416	416	416	416
1st Heat exchanger	m [kg]											
	L [mm]	1504	1029	1505	1505	1505	1505	1032	1505	1505	1505	1505
	B [mm]	1257	1257	1025	1125	1225	1425	1257	1025	1125	1225	1325
	H [mm]	150	150	150	150	150	150	150	150	150	150	150
2nd Heat exchanger	m [kg]											
	L [mm]	1504	1029	1505	1505	1505	1505	1032	1505	1505	1505	1505
	B [mm]	1257	1257	1025	1125	1225	1425	1257	1025	1125	1225	1325
	H [mm]	150	150	150	150	150	150	150	150	150	150	150
3rd Heat exchanger	m [kg]	-	-	-	-	-	-	-	-	-		210
	L [mm]	-	-	-	-	-	1505	1032	1505	1505	1505	1505
	B [mm]	-	-	-	-	-	1425	1257	1025	1125	1225	1325
	H [mm]	-	-	-	-	-	150	150	150	150	150	150
Frame	m [kg]	84	84	91	112	101	104	84	91	112	101	104
	L [mm]	1630	1630	2003	2003	2003	2008	1630	2003	2003	2003	2003
	B [mm]	1306	1306	1106	1106	1306	1506	1306	1106	1106	1306	1306
	H [mm]	460	460	460	460	460	400	460	160	460	460	160
Condensate receptacle	m [kg]											
	L [mm]	1450	1450	1905	1905	1905	2067	1452	1905	1905	1910	1910
	B [mm]	1098	1098	780	877	977	1170	1097	780	877	977	1080
	H [mm]	312	312	340	340	340	349	314	340	340	340	340

m Weight  
h Height  
B Width  
L Length

# Extent of delivery

## Component Dimensions: Trigon XXL SE/ECO/EVO

Component		SE-1300	SE-1500	SE-1700	SE-1900	EVO 1200	EVO 1400	EVO-1550	EVO 1700	EVO 2000
		ECO-1150	ECO-1300	ECO-	ECO-1600					
Burner	m [kg]									
	L [mm]	1505	2018	2018	2018	1505	2018	2018	2018	
	B [mm]	1393	1245	1345	1445	1393	1245	1345	1445	
	H [mm]	442	442	462	462	442	442	462	462	
1st Heat exchanger	m [kg]									
	L [mm]	1505	2018	2018	2018	1505	2018	2018	2018	
	B [mm]	1425	1253	1353	1453	1425	1253	1353	1453	
	H [mm]	150	150	150	150	150	150	150	150	
2nd Heat exchanger	m [kg]									
	L [mm]	1505	2018	2018	2018	1505	2018	2018	2018	
	B [mm]	1425	1253	1353	1453	1425	1253	1353	1453	
	H [mm]	150	150	150	150	150	150	150	150	
3rd Heat exchanger	m [kg]				-					
	L [mm]					1505	2018	2018	2018	
	B [mm]					1425	1253	1353	1453	
	H [mm]					150	150	150	150	
Frame	m [kg]	92	115	120	122	92	115	120	122	
	L [mm]	2008	2521	2521	2521	2008	2521	2521	2521	
	B [mm]	1506	1306	1506	1506	1506	1306	1506	1506	
	H [mm]	400	420	420	420	400	420	420	420	
Condensate receptacle	m [kg]									
	L [mm]	2074	2583	2582	2582	2074	2583	2582	2582	
	B [mm]	1171	641	1071	1171	1171	971	1071	1171	
	H [mm]	349	352	353	350	349	352	353	350	

m Weight  
h Height  
B Width  
L Length

# Norms and regulations

## General regulations

### Application

### Norms and regulations

### Additional national standards

#### General regulations

This documentation contains important information, which is a base for safe and reliable installation, commissioning and operation of the boiler. All activities described in this document may only be executed by authorized companies.

Changes to this document may be effected without prior notice. We accept no obligation to adapt previously delivered products to incorporate such changes.

Only original spare parts may be used when replacing components on the boiler, otherwise warranty will be void.

#### Application

The boiler may be used for heating and hot water production purposes only. The boiler should be connected to closed systems with a maximum temperature of 100 °C (high limit temperature), maximum setpoint temperature is 90 °C.

#### Norms and regulations

When installing and operating the boiler, all applicable norms (European and local) should be fulfilled:

Local building regulations for installing combustion air and flue gas systems;  
Regulation for connecting the boiler to the electrical appliance;  
Regulations for connecting the boiler to the local gas network;  
Norms and regulations according to safety equipment for heating systems;  
Any additional local laws/regulations with regard to installing and operating heating systems.

This boiler is CE approved and applies to the following European standards:

- **2016/426/EEC** Gas appliances regulation.
- **92/42/EEC** Efficiency directive
- **2009/142/EEC** Gas appliance directive.
- **2004/108/EEC** EMC directive.
- **2006/95/EEC** Low voltage directive.
- **EN 15502-1** Gas-fired central heating boilers –Part 1: General requirements and tests.
- **EN 15502-2-1** (Gas-fired central heating boilers –Part 2-1: Specific standard for type C appliances and type B2, B3 and B5 appliances of a nominal heat input not exceeding 1000 kW).
- **EN 55014-1** Electromagnetic compatibility- Requirements for household appliances, electric tools and similar apparatus - Part 1: Emission.
- **EN 55014-2** Electromagnetic compatibility- Requirements for household appliances, electric tools and similar apparatus - Part 2: Immunity - Product family standard.
- **EN 61000-3-2** Electromagnetic compatibility (EMC) - Part 3-2: Limits - Limits for harmonic current emissions (equipment input current 16 A per phase).
- **EN 61000-3-3** Electromagnetic compatibility (EMC) - Part 3-3: Limitation of voltage changes, voltage fluctuations and flicker in public low voltage supply systems, for equipment with rated current 16 A per phase and not subject to conditional connection.
- **EN 60335-1** Household and similar electrical appliances - Safety - Part 1: General requirements.

- **EN 60335-2-102** Household and similar appliances - Safety - Part 2-102: Particular requirements for gas, oil and solid-fuel burning appliances having electrical connections.
- **EN 50165** Electrical equipment of non-electric appliances for household and similar purposes. Safety requirements.
- **EN 12828 / DIN 4751-2** Heating systems in buildings - Design for water-based heating systems / Medium temperature hot water systems (mthws) with a boiler flow temperature up to 120°C - specification for sealed systems using thermostatic control - safety equipment.

#### Additional national standards

##### Germany:

– RAL - UZ 61 / DIN 4702-8

##### Switzerland:

– SVGW

##### Austria:

– Kurzgutachten 15a V-BG

##### Belgium:

– NOx certification

##### France:

– Arrête du 02 Aout 1977 - 300mbar gas pressure with accessorie kit (only TRIGON XXL ECO + EVO)

##### Italy:

– Star level certification  
“Legge 10” 1991

# Norms and regulations

## Maintenance

### Fuel

### Combustion air

### Water quality

#### Maintenance

Regular maintenance is necessary to secure a safe and economical operation of the installation. For the TRIGON XXL, one annual maintenance visit is recommended. During this visit, the proper functioning of the complete heating system should be checked as well.

#### Fuel

The gas condensing boiler TRIGON XXL is applicable for gases G20, G25, G30 and G31. Factory settings are always done for G20. For other types of natural gas, a correction can be made on the gas valve. For LPG, it's necessary to fit a restriction plate (included in delivery) before operating the boiler.

The TRIGON XXL can work with gas pressures up to 100 mbar. In case of a gas pressure above 100 mbar, a pressure regulator should be fitted in the gas line (available as accessory).

The gas consumption and gas pressures of the different gases can be found in the chapter „Technical data“.

#### Combustion air

The gas condensing boiler TRIGON XXL can be used in both non-roomsealed and roomsealed applications. The combustion air to the boiler shouldn't contain high concentrations of dust and/or halogen, as they can damage the heat exchanger surface. Especially in buildings, where chemicals are used, the combustion air facility should prevent these chemicals to enter the boiler.

The different room sealed connection possibilities the TRIGON XXL is approved for, can be found in the chapter „Flue gas system“.

#### Water quality

The lifetime of the complete heating system is affected by the water quality. Additional costs for water treatment of an installation are always lower than repairing costs for damage created by poor water quality.

The following water quality levels must be respected at all times for warranty claiming. Damage to the boiler due to poor water quality will not be taken under warranty.

The system should be filled with water with a PH value between 7,0 and 9,5. The chloride -, sulphide - and nitride value of the water should not exceed 50 mg/l. Entry of oxygen by diffusion should be prevented at all times. Damage to the heat exchanger because of oxygen diffusion will not be taken under warranty.

In installations with higher water volumes, it's necessary to respect the maximum filling and additional volumes with corresponding hardness values as stated in the german VDI2035 standard. In the table you can find the nominal values for filling and additional water for the TRIGON XXL according to the the VDI2035.

The table at the left gives an indication of the relation between the water quality and the maximum water filling volume during the lifetime of the boiler. Consult the original text of the VDI2035 for more detailed information.

Constant entry of oxygen in the installation should be avoided. The system water pressure should be higher than the atmospheric pressure in all parts of the installation. Underfloor heating components without oxygen diffusion barrier should never be used. When they're used anyway, a system separation (e.g. with plate heat exchanger) is compulsory.

TOTAL HEATING OUTPUT [kW]	Accepted hardness related to specific volume of installation		
	SPECIFIC VOLUME		
	< 20 l/kW	≥ 20 l/kW - < 50 l/kW	≥ 50 l/kW
50kW - ≤ 200kW	≤ 11.2°dH (2.0 mol/m <sup>3</sup> )	≤ 8.4°dH (1.5 mol/m <sup>3</sup> )	≤ 5.6°dH (1.0 mol/m <sup>3</sup> )
200kW - ≤ 600kW	≤ 8.4°dH (1.5 mol/m <sup>3</sup> )	≤ 5.6°dH (1.0 mol/m <sup>3</sup> )	≤ 2.8°dH (0.5 mol/m <sup>3</sup> )
600kW - ≤ 1200kW	≤ 5.6°dH (1.0 mol/m <sup>3</sup> )	≤ 2.8°dH (0.5 mol/m <sup>3</sup> )	≤ 0.11°dH (0.02 mol/m <sup>3</sup> )
> 1200kW	≤ 2.8°dH (0.5 mol/m <sup>3</sup> )	≤ 0.11°dH (0.02 mol/m <sup>3</sup> )	≤ 0.11°dH (0.02 mol/m <sup>3</sup> )

Concentrate Ca(HCO <sub>3</sub> ) <sub>2</sub>		Capacity of installation Q (kW)							
		600	800	1000	1200	1400	1600	1800	2000
mol/ m <sup>3</sup>	d°H	Maximum water (re)fill volume V <sub>max</sub> [m <sup>3</sup> ]							
≤0.5	≤2.8	-	-	-	75.1	87.6	100.2	122.7	125.2
1.0	5.6	-	-	-	37.6	43.8	50.1	56.3	62.6
1.5	8.4	12.0	16.7	20.9	25.0	29.2	33.4	37.6	41.7
2.0	11.2	9.4	12.5	15.7	18.8	21.9	25.0	28.2	31.3
2.5	14.0	7.5	10.0	12.5	15.0	17.5	20.0	22.5	25.0
≥3.0	≥16.8	6.3	8.3	10.4	12.5	14.6	16.7	18.8	20.9

# Norms and regulations

## Noise protection Antifreeze

### Noise protection

The gas condensing boiler TRIGON XXL is equipped with a patented premix burner. The noise level of this very quiet premix burner is extremely low in comparison to conventional gas burners. Therefore no further measures have to be taken for noise protection in the boiler room.

The TRIGON XXL is supplied with adjustable wheels, which also prevent the transmission of vibration noise from the boiler into the building.

Once the boiler is in the correct position, turn anti-clockwise the regulator (A) or the nut (B) to let the feet out, till the boiler is set in the right height.

Noise created by system components (e.g. pumps) should be taken care of with external measurements, in case of higher noise level requirements.

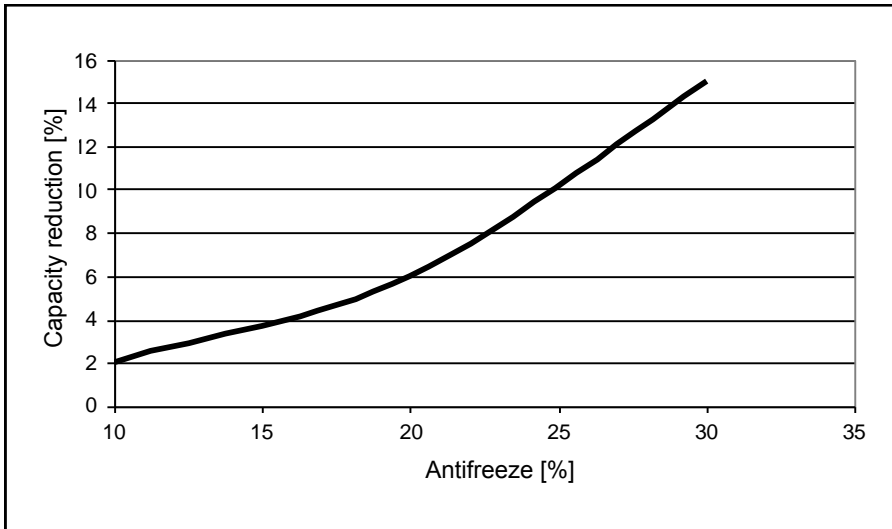
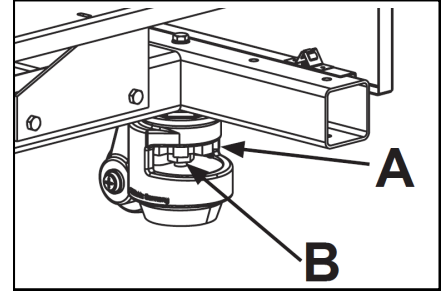

### Antifreeze

The TRIGON XXL can be used with the antifreeze type Shell Antifreeze Concentrate. The concentration of the antifreeze in the system affects the maximum capacity the boiler can work on. The relation between antifreeze concentration and capacity reduction of the boiler can be found in the graph. The maximum percentage of antifreeze should not exceed 30%.

# Flue gas system

## Requirements and regulations Materials

### Requirements and regulations

Regulations for the construction of flue gas systems are very different for each country. It should be ensured that all national regulations with regard to flue gas systems are respected. The most important national norms can be found in the chapter „Norms“.

A separate condensate drain for the chimney is not necessary, as the condensate can enter the drain via the syphon connection of the boiler.

Pay attention to the following recommendations when dimensioning a flue gas system:

- Only approved flue gas material may be used.
- The flue gas system must be properly calculated to ensure a safe functioning of the system.
- Flue gas system components should be removable for maintenance purposes.
- Horizontal flue gas ways must be mounted under an angle of 3° minimum.

The installer is responsible to apply the correct diameter, length and type of flue gas system. If any questions arise during the calculation contact your local manufacturer office for more information. You have to take in consideration the following material requirements:

	Pressure class	Temperature class	Condensate resistant	Corrosion class	Fire resistant
Flue resistance <200Pa	P1	Min:T120	W	V1,V2 or Vm	E or higher
200Pa<Flue resistance<5000Pa	H1	Min:T120	W	V1,V2 or Vm	E or higher

### Materials

Exclusively materials, which are heat resistant and resistant to flue gases and aggressive condensate, may be used.

The TRIGON XXL has an integrated high limit thermostat function for the flue gases. When the fluegas temperature exceeds 100°C, the burner is switched off. With this function, an additional (external) safety device is not necessary.

	Plastic PP	Stainless steel
Temperature class	T120	T250
Pressure class	P1	-
Corrosion class	W1	W1

# Flue gas system

## Flue gas data

### Flue gas data

Boiler Type	Nominal heat Output		Nominal heat input		Flue Gas Connection	Co <sub>2</sub> Level		Flue gas temperature		Flue gas Quantity		Max Permissible flue Resistance
	max	min	max	min		max	min	max	min	max	min	
TRIGON XXL	kW		kW		mm	%		°C		g/s		Pa
SE 650	650	164	702	176	300 ± 1	10.0 ± 0.2	9.3 ± 0.2	165 ± 2	70 ± 2	309,9	84,4	150
SE 750	726	183	784	196	350 ± 1					346,1	94,0	
SE 850	849	213	917	229	350 ± 1					404,8	109,8	
SE 1000	961	242	1038	260	400 ± 1					458,2	124,7	
SE 1100	1073	270	1159	290	400 ± 1					511,6	139,1	
SE 1200	1184	298	1279	320	450 ± 1					564,6	153,5	
SE 1300	1296	326	1400	350	450 ± 1					618,0	167,9	
SE 1500	1481	373	1600	400	500 ± 1					706,3	191,8	
SE 1700	1666	419	1800	450	500 ± 1					794,6	215,8	
SE 1900	1851	466	2000	500	500 ± 1					882,9	239,8	
ECO 650	615	175	653	187	350 ± 1	10.0 ± 0.2	9.3 ± 0.2	155 ± 2	65 ± 2	288,3	89,9	150
ECO 750	719	204	764	218	350 ± 1					337,3	104,8	
ECO 850	814	231	865	247	400 ± 1					381,9	118,8	
ECO 950	909	258	966	276	400 ± 1					426,5	132,7	
ECO 1050	1003	285	1066	305	400 ± 1					470,7	146,7	
ECO 1150	1097	311	1166	333	450 ± 1					514,8	160,1	
ECO 1300	1255	356	1333	381	450 ± 1					588,6	183,2	
ECO 1450	1411	400	1449	428	450 ± 1					661,9	205,8	
ECO 1600	1568	445	1666	476	450 ± 1	735,6	228,9					
EVO 700	639	182	653	187	300 ± 1	10.0 ± 0.2	9.3 ± 0.2	85 ± 2	65 ± 2	295,1	89,9	150
EVO 800	747	212	764	218	350 ± 1					345,3	104,8	
EVO 900	846	241	865	247	350 ± 1					390,9	118,7	
EVO 1000	945	269	966	276	400 ± 1					436,6	132,7	
EVO 1100	1043	297	1066	305	400 ± 1					481,8	146,6	
EVO 1200	1141	324	1166	333	450 ± 1					527,0	160,1	
EVO 1400	1304	371	1333	381	450 ± 1					602,5	183,2	
EVO 1550	1467	417	1449	428	450 ± 1					677,5	205,8	
EVO 1700	1630	464	1666	476	500 ± 1					753,0	228,8	
EVO 2000	1953	487	2000	500	500 ± 1							

# Flue gas system

## Dimensioning

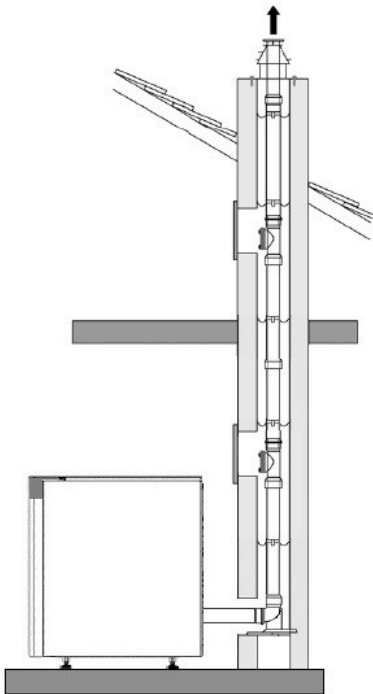

Calculation base:  
Total connection length in boiler room ≤ 1.5 m;  
1x 87°-bend

\* Based on straight pipe, open outlet

### Dimensioning

When dimensioning a flue gas system, it's necessary to perform a calculation check of the flue gas system in order to verify if the chosen system is applicable.

The following tables represent as an example of possible flue gas systems of TRIGON XXL SE, EVO and ECO series, including the maximum possible height of the system. These examples only give an indication of the possible heights, but they can **not** be used for official flue gas layout calculation. Each flue gas system must be calculated by an authorized company.

The maximum negative flue gas pressure, which doesn't affect the burner modulation ratio, is 30 Pa. Higher negative pressure will lead to limitation of the burner modulation ratio.

The maximum horizontal flue gas way is 20m. With horizontal ways longer than 20m, a faultless burner start in cold condition can not be guaranteed.

Type	Maximum permissible height* (h) of flue gas system in [m]					
	Ø250mm	Ø300mm	Ø350mm	Ø400mm	Ø450mm	Ø500mm
<b>SE 650</b>	23	50	50			
<b>SE 750</b>		47	50	50		
<b>SE 850</b>		34	50	50		
<b>SE 1000</b>			50	50	50	
<b>SE 1100</b>			40	50	50	
<b>SE 1200</b>			33	50	50	
<b>SE 1300</b>				46	50	50
<b>SE 1500</b>				36	50	50
<b>SE 1700</b>					45	50
<b>SE 1900</b>					36	50

Type	Maximum permissible height* (h) of flue gas system in [m]				
	Ø250mm	Ø300mm	Ø350mm	Ø400mm	Ø450mm
<b>EVO 700</b>	38	50	50		
<b>EVO 800</b>		50	50	50	
<b>EVO 900</b>		50	50	50	
<b>EVO 1000</b>			50	50	50
<b>EVO 1100</b>			50	50	50
<b>EVO 1200</b>			50	50	50
<b>EVO 1400</b>			49	50	50
<b>EVO 1550</b>			39	50	50
<b>EVO 1700</b>		17	31	50	50

Type	Maximum permissible height* (h) of flue gas system in [m]				
	Ø250mm	Ø300mm	Ø350mm	Ø400mm	Ø450mm
<b>ECO 650</b>	29	50	50		
<b>ECO 750</b>		50	50	50	
<b>ECO 850</b>		43	50	50	
<b>ECO 950</b>			50	50	50
<b>ECO 1050</b>			50	50	50
<b>ECO 1150</b>			50	50	50
<b>ECO 1300</b>			38	50	50
<b>ECO 1450</b>			30	50	50
<b>ECO 1600</b>			24	41	50

# Neutralisation

## General

### Neutralisation systems

#### Standard neutralisation system (DN)

#### Neutralisation system with pump (HN)

#### General

Condensate, created by the TRIGON XXL, should be drained into the public draining system. The condensate PH is between 3.0 and 3.5. National and/or local regulations have to be checked, in order to find out whether the condensate should be neutralised before entering the public draining system.

The maximum amount of condensate for each boiler type can be found in the chapter „Technical data“.

#### Neutralisation systems

The neutralisation systems can be placed in the bottom section of the boiler. The delivery of the system contains the following components:

- Granulate for first filling
- Connection hoses for inlet and outlet connection
- Boiler connection adapter

For the neutralisation two different systems are available:

#### Standard neutralisation system (DN)

The standard neutralisation system is used, when the public draining connection is at lower level than the boiler syphon connection.

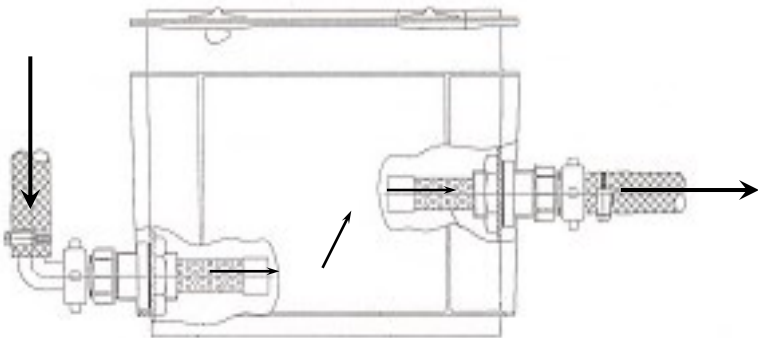

Type		DN2	DN3
Applicable for	[kW]	450	1500
Length	[mm]	420	640
Width	[mm]	300	400
Height	[mm]	240	240

#### Neutralisation system with pump (HN)

The neutralisation system with pump is used, when the public draining system is at higher level than the boiler syphon connection and the condensate needs to be transported to a higher level before draining is possible. The built-in pump of the neutralisation system takes care of the transport of the condensate.

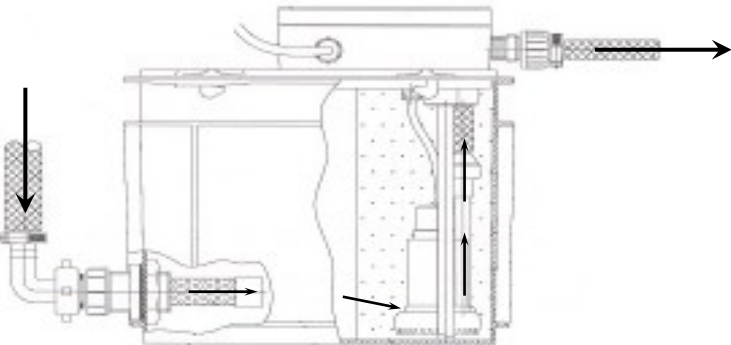

Type		HN 1.5	HN 2.5
Applicable for	[kW]	280	540
Length	[mm]	410	640
Width	[mm]	300	400
Height	[mm]	290	240
Power consumption pump	[W]	40	150
Pump head	[m]	6	3

# Hydraulic connection

## Hydraulic resistance

### ΔT-measurement

### Δp-measurement

## Water flow data TRIGON XXL SE

### Hydraulic resistance

The hydraulic resistance depends on the flow rate through the boiler and the boiler type. In the graph the resistance for a specific flow rate can be found.

The TRIGON XXL is able to control a speed controlled pump via PWM or a 0-10VDC signal. It makes the flow rate modulate in parallel with the burner load. The minimum flow rate, to which the pump is allowed to modulate with the burner load, is 30% of the nominal flow rate through the boiler for ECO and EVO versions, and 50% for SE versions.

The flow rate through the boiler can also be checked by calculation. This can be done with a ΔT as well as a Δp measurement.

### ΔT-measurement

Check the temperature difference over the boiler (ΔT flow-return) when the boiler is running on 100% load. The nominal ΔT is 20K and must be at least between 10K and 30K for secure boiler operation. An indication of the actual flow rate can be found with the following calculation (see table below for nominal data):

$$q_{\text{actual}} = (\Delta T_{\text{nominal}} / \Delta T_{\text{measured}}) * q_{\text{nominal}} \text{ [ m}^3\text{/h]}$$

### Δp-measurement

Check the pressure difference over the boiler (Δp flow-return) when the boiler pump is running (burner on is not required). The nominal Δp for each boiler type can be found in the table below, actual Δp must be within:  $0.45 * \Delta p_{\text{nom}} \leq \Delta p \leq 4 * \Delta p_{\text{nom}}$ . An indication of the actual flow rate can be found with the following calculation (see table below for nominal data):

$$q_{\text{actual}} = \sqrt{(\Delta p_{\text{measured}} / \Delta p_{\text{nominal}})} * q_{\text{nominal}} \text{ [m}^3\text{/h]}$$



TRIGON XXL SE		650	750	850	1000	1100	1200	1300	1500	1700	1900
Nominal flow rate	m <sup>3</sup> /h	27,9	31,2	36,5	41,3	46,1	50,9	55,7	63,7	71,6	79,6
ΔT at nominal flow rate	K	20									
Δp at nominal flow rate	kPa	46	53	36	43	50	58	91	60	130	165
Min. flow rate*	m <sup>3</sup> /h	14,0	15,6	18,2	20,6	23,0	25,4	27,8	31,8	35,7	39,7
Δp at min. flow rate*	kPa	11,5	13,25	9	10,75	12,5	14,5	22,75	15	32,5	41,25

\*50% of the nominal flow rate

# Hydraulic connection

## Water flow data TRIGON XXL ECO

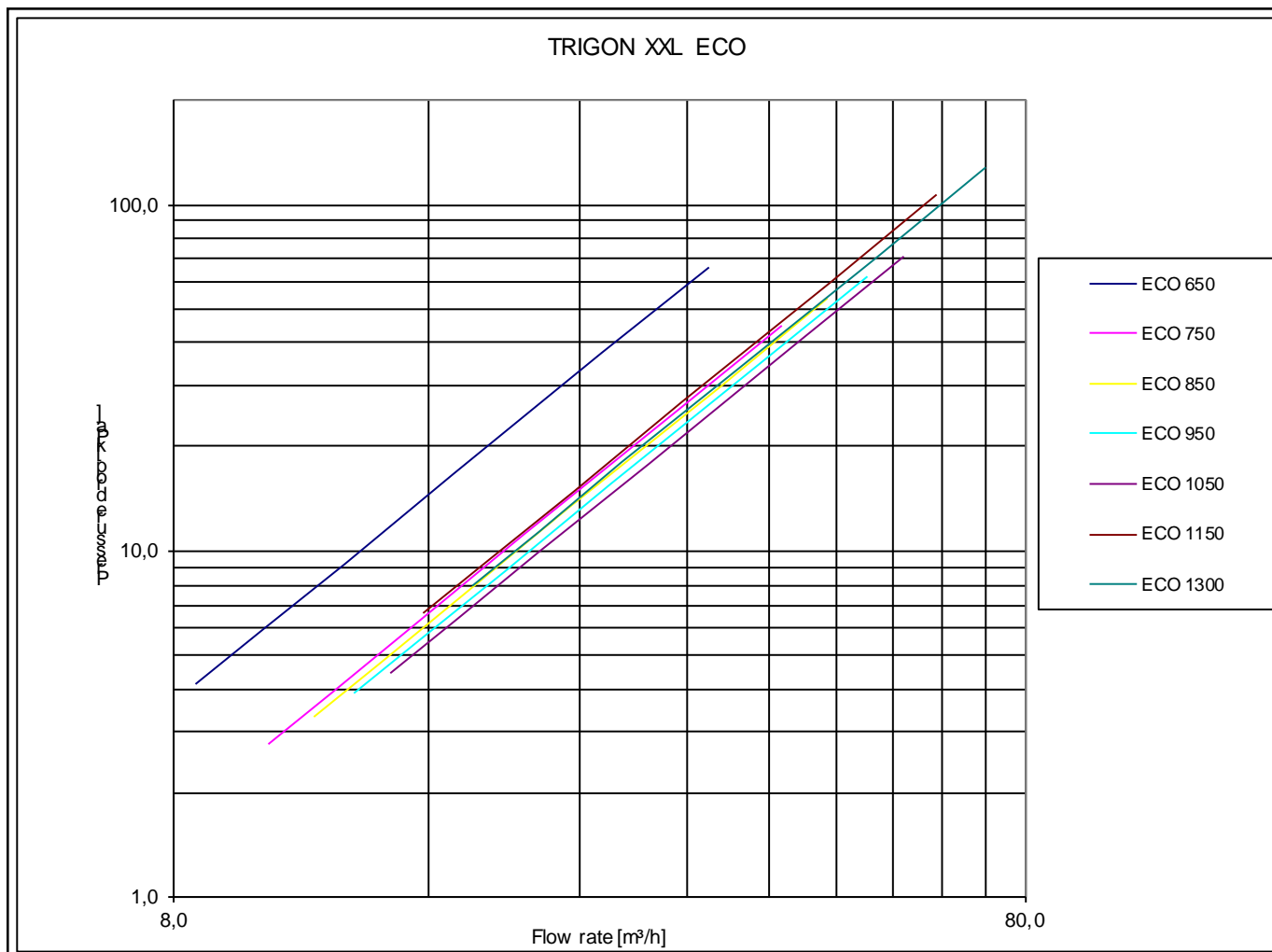

TRIGON XXL ECO		650	750	850	950	1050	1150	1300	1450	1600
Nominal flow rate	m <sup>3</sup> /h	26,4	30,9	35,0	39,1	43,1	47,2	53,9	60,7	67,4
$\Delta T$ at nominal flow rate	K	20								
$\Delta p$ at nominal flow rate	kPa	37	25	30	35	40	60	72	93	114
Min. flow rate*	m <sup>3</sup> /h	7,9	9,3	10,5	11,7	13,0	14,2	16,2	18,2	20,3
$\Delta p$ at min. flow rate*	kPa	3,3	2,3	2,7	3,2	3,6	5,4	6,5	8,4	10,3

\*30% of the nominal flow rate

# Hydraulic connection

## Water flow data TRIGON XXL EVO

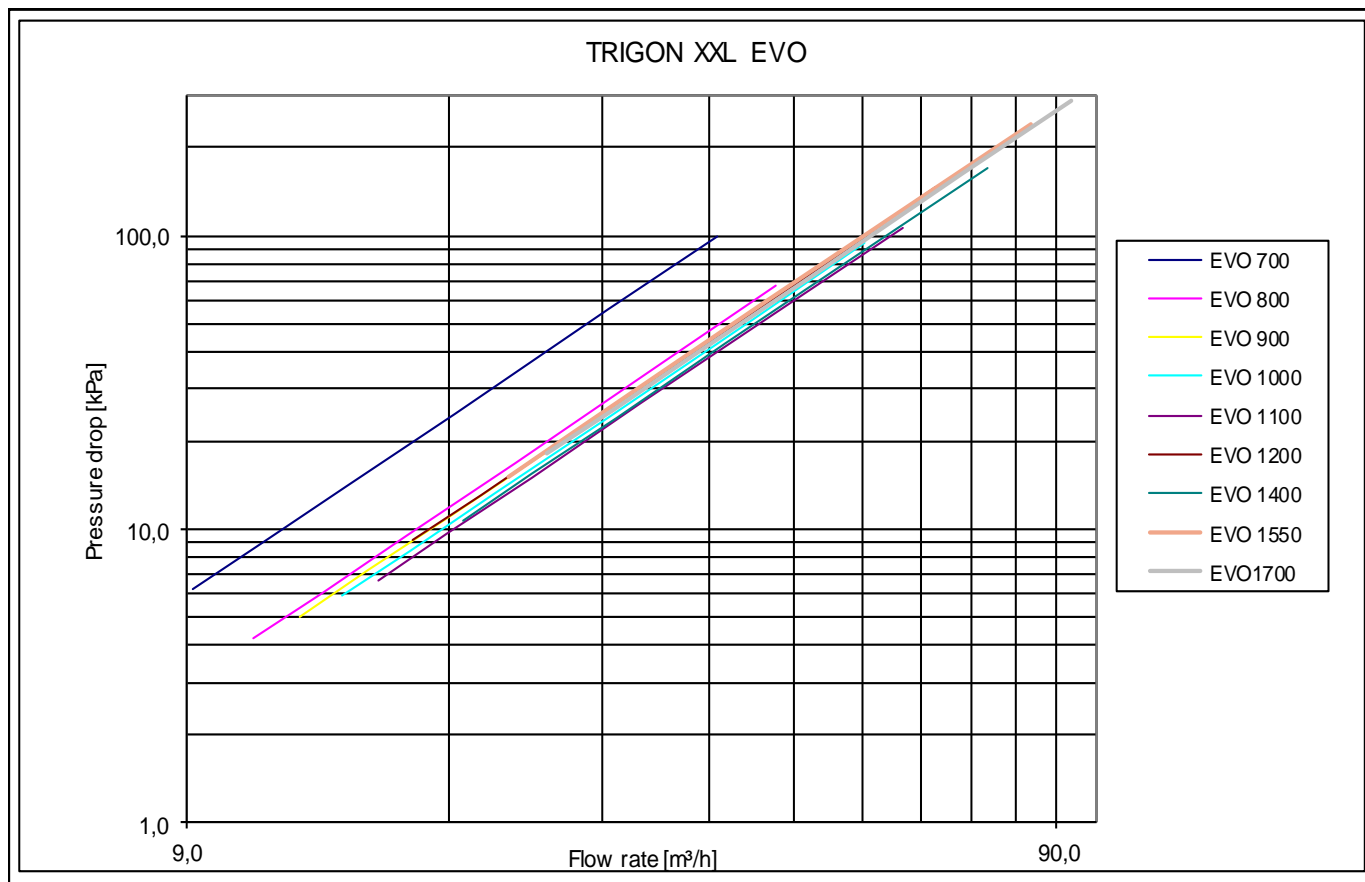

TRIGON XXL EVO		700	800	900	1000	1100	1200	1400	1550	1700
Nominal flow rate	m <sup>3</sup> /h	27,5	32,1	36,4	40,6	44,8	47,2	53,9	60,7	67,4
ΔT at nominal flow rate	K	20								
Δp at nominal flow rate	kPa	56	38	45	53	60	82	96	136	162
Min. flow rate*	m <sup>3</sup> /h	8,3	9,7	10,9	12,2	13,5	14,7	16,8	18,9	21,1
Δp at min. flow rate*	kPa	5,0	3,4	4,1	4,8	5,4	7,4	8,6	12,2	14,6

\*30% of the nominal flow rate

# Hydraulic connection

## Hydraulic connection into a system

### Standard

### Bypass

#### Hydraulic connection into a system

The TRIGON XXL must be connected in such a way, that a minimum flow rate of 50% of the nominal flow rate of SE versions and 30% of the nominal flow rate of ECO and EVO version can be ensured at all times, independent from the flow rate in the secondary system. This can be achieved by using one of the following 3 possibilities:

- Standard, with low loss header or plate heat exchanger
  - Bypass, with integrated minimum flow rate by Bypass pump\*
  - Split System, with 2 return connections for best possible efficiency (warm and cold return)\*
- \* only applicable in single boiler installations

Details to the 3 possibilities mentioned above, can be found in the next sections.

#### Standard

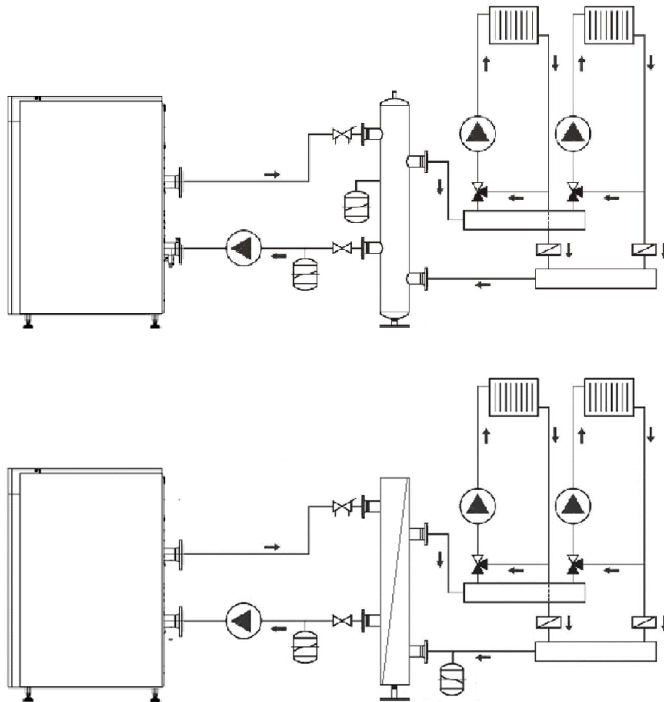

#### Standard

This is the most common way to connect the boiler to the system. By using a low loss header or plate heat exchanger a minimum flow rate can be ensured at all times, independent from the flow rate in the secondary system. The boiler pump is available as a speed controlled version. The speed controlled pump modulates the flow rate in the primary system in parallel with the burner load. This ensures the lowest possible return temperature to the boiler for high efficiency usage. Details of the available pump kits can be found in the chapter „Accessories“.

#### Bypass

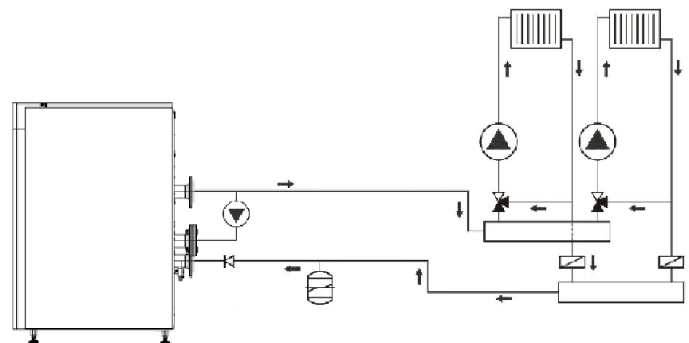

#### Bypass

In single boiler installations, the TRIGON XXL can also be used without low loss header or plate heat exchanger. For this solution a bypass kit is available as accessory to the standard boiler. The bypass is connected between the flow connection and the second return connection of the boiler. The performance of the bypass pump is very low when the system flow rate is high. As soon as the system flow rate decreases, the bypass pump performance increases to ensure a minimum flow rate through the boiler.

**The bypass pump does not transport the water from the boiler into the system. The system pump should overcome the boiler resistance at nominal flow rate to transport the water from the boiler into the system and vice versa.**

Details of the available pump kits can be found in the chapter „Accessories“.

# Controls

## Basic controls and connections Control by building management system Boiler enable signal Temperature or capacity setpoint

### Basic controls and connections

The standard version of the TRIGON XXL is equipped with a LMS14 boiler management unit. This controller controls both the burner safety operation and the temperature regulation of the boiler. The LMS14 includes the following functions:

- Electronic high limit thermostat
- Electronic flue gas temperature limiter
- Primary boiler pump control (via relay)
- Primary sanitary hot water pump control (use of relay necessary when > 1A)
- Interlock input
- Lockout input
- Alarm output signal
- Boiler enable signal
- 0-10VDC temperature or capacity setpoint (programmable)
- 0-10VDC capacity feedback or 10V contact for external gas valve (programmable)
- Temperature control central heating via PID controller
- Temperature control sanitary hot water (hot water priority)
- Weather compensation (with optional outdoor sensor)
- Connection possibility for external gas valve and/or room fan. See chapter "Accessories" for combinations with an OK/Alarm contact
- Master/Slave cascade control (with optional BUS communication modules).

When additional control of secondary heating zones or cascade systems are required, the TRIGON XXL can be extended with different additional controls. Explanation of these controls can be found in the next sections.

### Control by building management system

The TRIGON XXL can be connected to a building management system. This can be done by using (one of) the following connections:

### Boiler enable signal, terminals 116-117 (volt free)

The boiler enable signal is provided with a jumper from the factory. When connecting a (volt free!!!) external signal, the jumper must be removed.

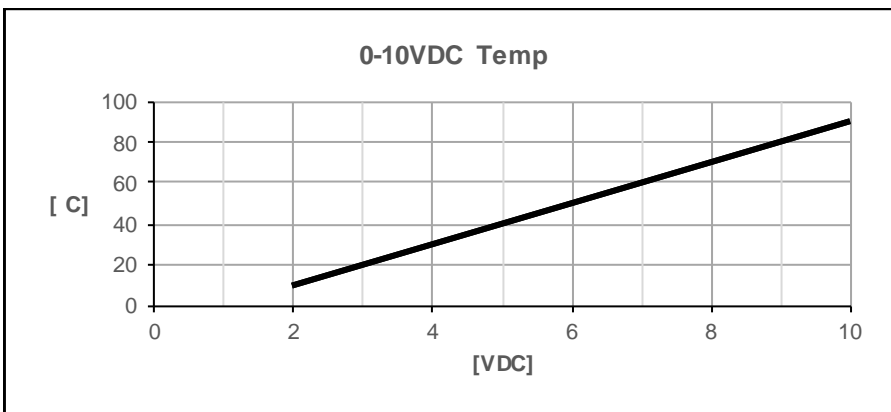

### Temperature or capacity setpoint, terminals 112-113 (0-10VDC)

The TRIGON XXL can be controlled via a temperature or capacity setpoint. The signal values are programmable, from the factory the contact is programmed for temperature setpoint with settings as shown in the graphic.

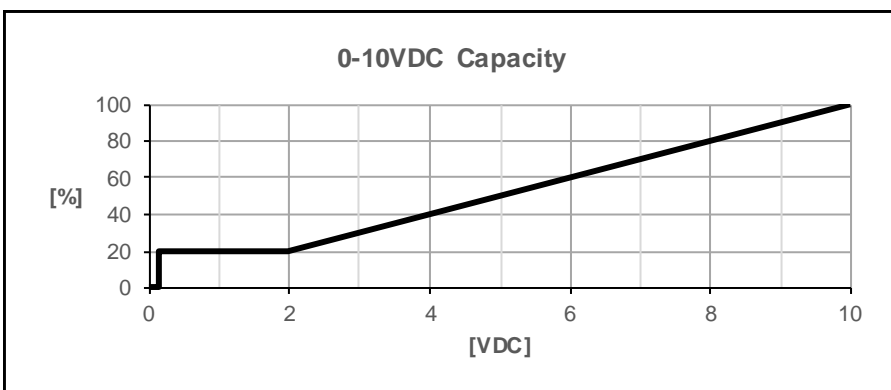

When controlling the boiler via a capacity setpoint, it's highly recommended to control the primary boiler pump with the internal pump control of the LMS14 boiler controller. The minimum flow rate through the boiler must be respected at all times. The nominal  $\Delta T$  is 20K and should be at least within 15K-30K at full load to secure a safe boiler operation.

**Attention:** from 0,15V the burner will work on minimum load.

# Controls

## Capacity feedback signal OK/Alarm output signal

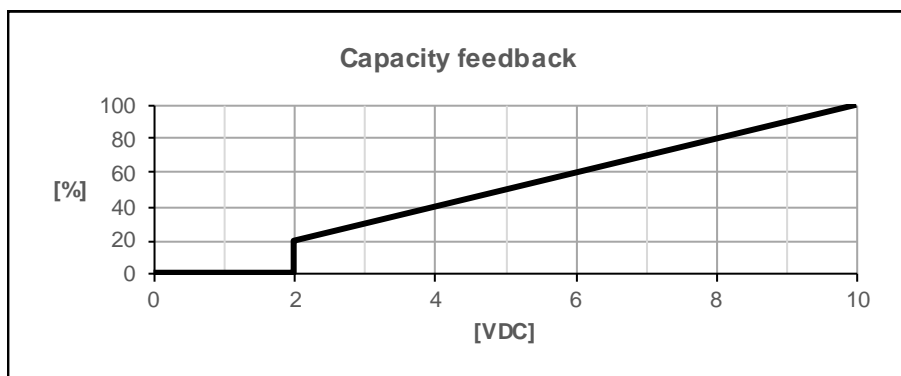

### Capacity feedback signal, terminals 120-121 (0-10VDC)

This signal is available at the mentioned terminals, when the burner is active. The following graph shows the value of the signal.

**Attention:** max. Current =2,7 ma

**Alarm output signal, terminals 9 (L) - 10 (N) (230VAC) or extension module AVS75 (contact QX21) when combined with external gas valve and/or room fan or gas leakage tester.**

The boiler provides an alarm signal at terminal 9 (or QX21).

# Controls

## Heating zone control Cascade control

---

### Heating zone control

The TRIGON XXL can be extended with an AVS75 controller for extended heating zone control. The AVS75 enables weather compensated operation of one mixed heating zone.

For room temperature optimisation of each heating zone, an additional roomunit QAA75 can be connected via bus connection. The values for the specific heating zone can then be displayed and changed on the room unit.

In case of heating systems with more than three heating zones, an additional kit with Logon B G2Z2 controller in a wall hung box is available. These kits can be used in a modular way up to a maximum of 8 heating zones.

See chapter "Installation examples" for more details regarding connections of pumps, sensors, etc.

### Cascade control

The TRIGON XXL can be controlled in a cascade system of maximum 8 boilers. This can be done by using the integrated Master/Slave cascade functionality in combination with an optional BUS communication device OCI345 (see chapter "Accessories" for more details).

The LMS14 includes an intelligent cascade control, which allows free programming of boiler sequence after certain hours of operation.

See chapter "Installation examples" for more details regarding connections of pumps, sensors, etc.

# Accessories

## System selection

---

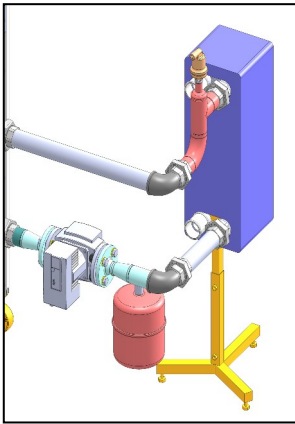

The TRIGON XXL is supplied from the factory with LMS14 boiler management unit. Additionally a wide variation of accessory kits is available. The accessory kits are specially designed for the TRIGON XXL and are very easy to combine with the boiler to create a complete system solution.

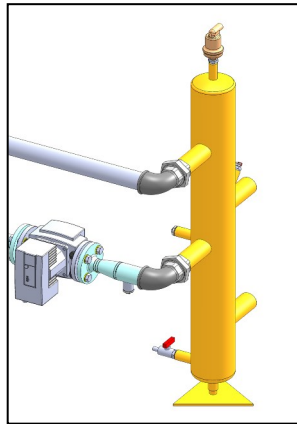

### System selection

The plug & play accessory kits enable a very easy selection and assembly of a complete system solution. As the kits can be combined very easily, a wide variation of solutions can be made by just picking the right kits from the selection table. The accessory kits are pre-assembled and can be mounted to the boiler very quickly. The accessory kits are built in a modular way. The kits are listed on the next pages.

# Accessories

## Safety devices

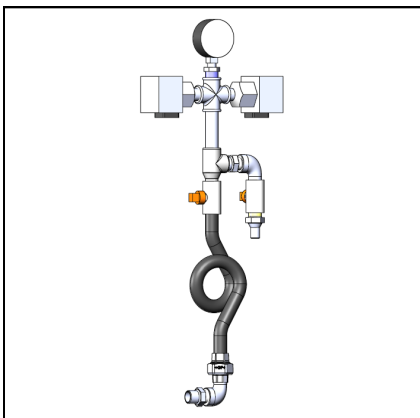

### 2x max. Water pressure switch + pressure gauge

The pre-assembled kit can be connected with a 90° bend to the flow connection of the boiler.

All components are electrically wired, and can be connected directly to the terminals in the boiler. Consult the supplied instructions for more details.



### Max. gas pressure switch

The kit includes a gas pressure switch, which can be connected directly to the gas line inside the boiler. The gas pressure switch is electrically wired, and can be connected directly to the terminals in the boiler. Consult the wiring diagram for more details.



### External high limit thermostat

There is a connection point for the high limit stat on the boiler flow pipe. The high limit thermostat is electrically wired, and can be connected directly to the terminals in the boiler. Consult the supplied instructions for more details.



### Gas valve leakage tester

The kit includes a gas valve leakage tester, which can be connected directly to the gas valve in the boiler. The gas valve leakage tester is electrically wired, and can be connected directly to the terminals in the boiler. Consult the wiring diagram for more details.

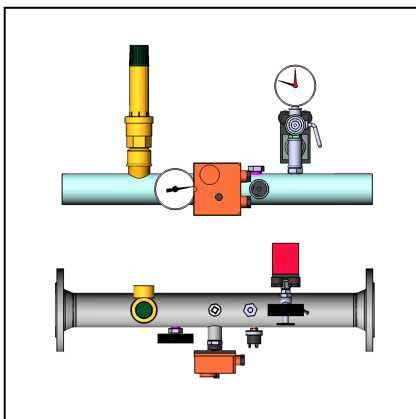

### INAIL-Set (Italy only)

The kit includes a pipe with safety valve, pressure gauge, thermometer, thermostat and pressure switches.

# Accessories

## Hydraulics

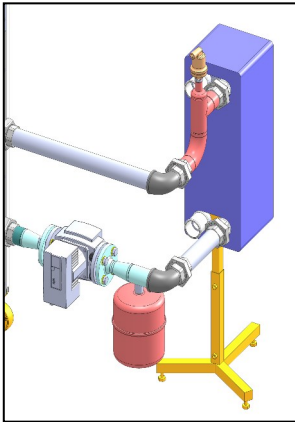

### Plate heat exchanger + connection kit

The kit contains a plate heat exchanger including connection material, automatic de-aerator, expansion vessel and flow pipe.

The following data can be used for the dimensioning of the secondary system.

TRIGON XXL	$\Delta T=10K$		$\Delta T=15K$		$\Delta T=20K$	
	[m <sup>3</sup> /h]	[kPa]	[m <sup>3</sup> /h]	[kPa]	[m <sup>3</sup> /h]	[kPa]
SE 650	56,0	184,0	37,3	81,8	28,0	46,0
SE 750	62,3	212,0	41,5	94,2	31,1	53,0
SE 850	72,8	144,0	48,6	64,0	36,4	36,0
SE 1000	82,5	172,0	55,0	76,4	41,2	43,0
SE 1100	92,1	200,0	61,4	88,9	46,0	50,0
SE 1200	101,6	232,0	67,7	103,1	50,8	58,0
SE 1300	111,2	364,0	74,1	161,8	55,6	91,0
SE 1500	127,1	240,0	84,7	106,7	63,5	60,0
SE 1700	143,0	520,0	95,3	231,1	71,5	130,0
SE 1900	158,9	660,0	105,9	293,3	79,4	165,0
ECO 650	52,9	148,0	35,3	65,8	26,5	37,0
ECO 750	61,9	100,0	41,3	44,4	31,0	25,0
ECO 850	70,1	120,0	46,7	53,3	35,1	30,0
ECO 950	78,3	140,0	52,2	62,2	39,2	35,0
ECO 1050	86,4	160,0	57,6	71,1	43,2	40,0
ECO 1150	94,5	240,0	63,0	106,7	47,3	60,0
ECO 1300	108,1	288,0	72,0	128,0	54,0	72,0
ECO 1450	121,5	372,0	81,0	165,3	60,8	93,0
ECO 1600	135,0	456,0	90,0	202,7	67,5	114,0
EVO 700	55,0	296,0	36,7	131,6	27,5	74,0
EVO 800	64,4	160,0	42,9	71,1	32,2	40,0
EVO 900	72,9	180,0	48,6	80,0	36,4	45,0
EVO 1000	81,4	268,0	54,3	119,1	40,7	67,0
EVO 1100	89,8	312,0	59,9	138,7	44,9	78,0
EVO 1200	98,3	328,0	65,5	145,8	49,1	82,0
EVO 1400	112,3	384,0	74,9	170,7	56,2	96,0
EVO 1550	126,3	544,0	84,2	241,8	63,2	136,0
EVO 1700	140,4	648,0	93,6	288,0	70,2	162,0
EVO 2000	168,2	864,0	112,1	384,0	84,1	216,0

# Accessories

## Hydraulics

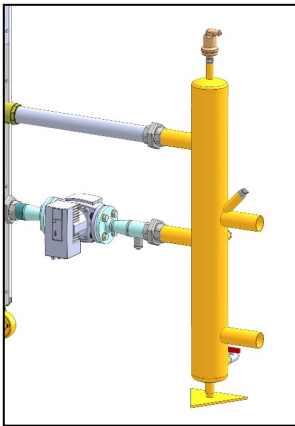

### Low loss header + connection kit

#### Mono header

The kit contains a low loss header including connection material, automatic de-aerator, plunge (for header sensor) and fill/drain valve on the bottom connection.

#### Duo header

The kit contains a duo header including automatic de-aerator, plunge (for header sensor) and fill/drain valve on the bottom connection. The duo header kit doesn't contain connection material, because of the wide variation of positioning possibilities. The connections have to be made on site.

Insulation for the mono and duo headers is available as accessory.

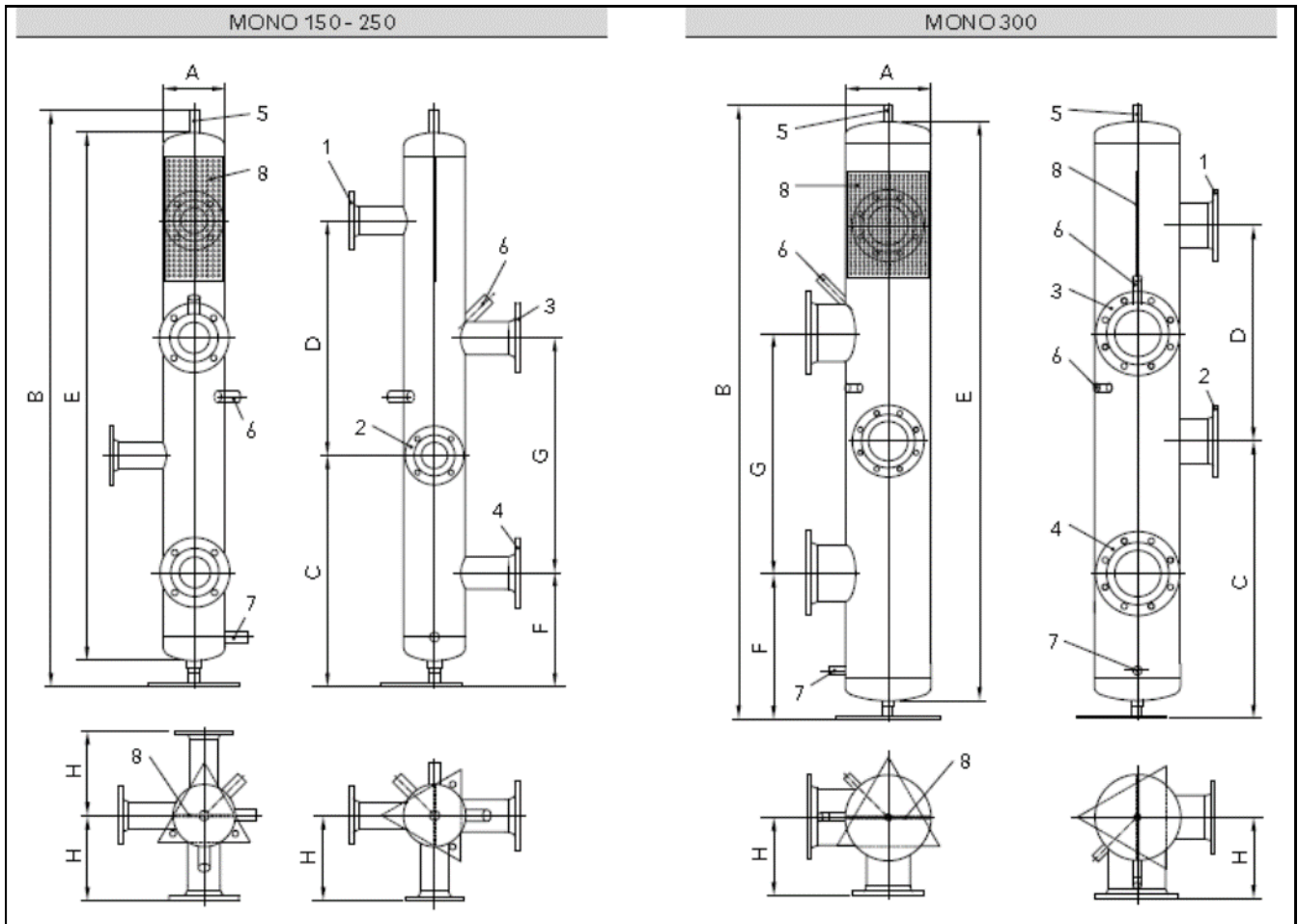

SAP Code		64200906	3580799	3590053	64200903	64200902	3581393	3590120
A Diameter	DN	150	150	200	200	250	300	200
B Total height	[mm]	1570	1570	1570	1570	2190	2340	2010
C Height to boiler return	[mm]	630	630	630	630	1065	1065	630
D Boiler flow/return distance	[mm]	640	640	640	640	710	810	880
E Header body height	[mm]	1440	1440	1453	1452	2060	2210	1880
F Height to system return	[mm]	310	310	310	310	568	560	310
G System flow/return distance	[mm]	640	640	640	640	842	910	760
H Mid to flange distance	[mm]	234	234	260	260	287	312	260

# Accessories

## Hydraulics

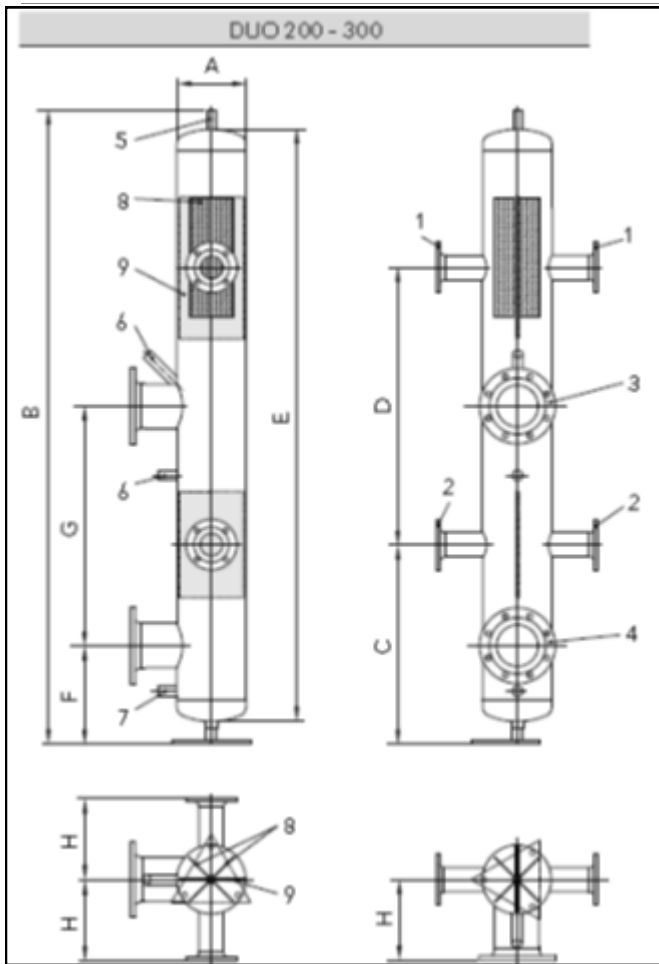

SAP Code		12034679	12034690	12034701	3581392
<b>A</b> Diameter	DN	250	250	300	300
<b>B</b> Total height	[mm]	2400	2400	2400	2400
<b>C</b> Height to boiler return	[mm]	630	630	630	1065
<b>D</b> Boiler flow/return distance	[mm]	1080	1080	1080	994
<b>E</b> Header body height	[mm]	2270	2270	2270	2270
<b>F</b> Height to system return	[mm]	310	310	310	568
<b>G</b> System flow/return distance	[mm]	850	850	850	994
<b>H</b> Mid to flange distance	[mm]	287	287	312	312

# Accessories

## Hydraulics

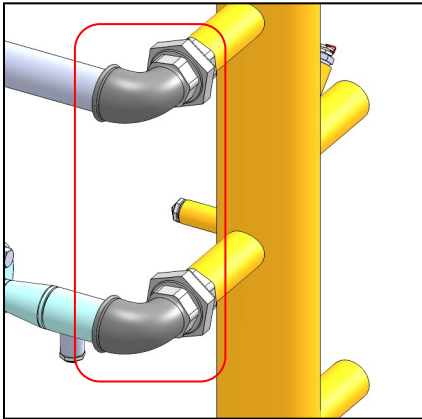

### 2x Bends 90°

The kit contains 2 90° bends to allow a flexible set up.

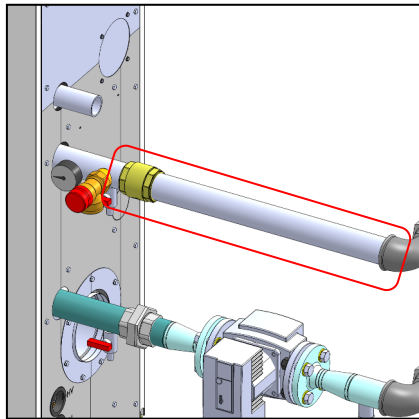

### Flow adapter + NRV

The kit contains a flow adapter (extension part for the flow pipe) and a non-return valve. The total length is the same as the length of the pump kit.

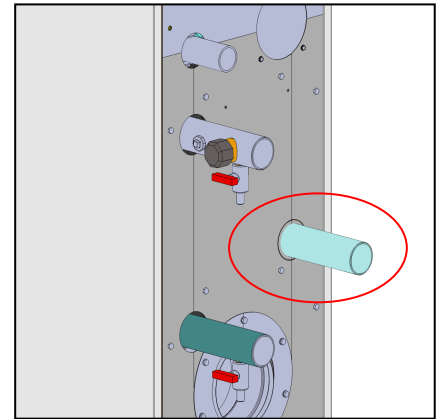

### 2nd Return connection

The kit contains a pipe which can be used as 2nd (hot) return connection on the boiler. See chapter "Hydraulic system" for calculation of the system.

### Safety valve (3 or 6 bar) + pressure gauge

The kit includes a safety valve (3 or 6 bar) and a pressure gauge. See the table on page 47.

### Bypass

The kit includes a bypass pump including connection material. The kit is to be connected between the flow and 2nd return connection of the boiler. The bypass pump is electrically wired, and can be connected directly to the terminals in the boiler. Consult the supplied instructions for more details. See the pages 40-43.

### Speed controlled pump

The kit includes a speed controlled pump including connection material with connection possibility for an expansion vessel. The following table shows the hydraulic data of the boiler and the boiler pump. The pump is electrically wired, and can be connected directly to the terminals in the boiler. Consult the supplied instructions for more details. See next page for the pump curves. See the pages 40-43.

# Accessories

## Controls



**RECEIVER AVS71.390/109 WIRELESS** The kit contains an AVS71 wireless receiver. When connected to the boiler, it can transmit data between wireless room units QAA78 and/or wireless outdoor sensors (QAC34 + AVS13).

**Attention:** the mounting position should be chosen as such that uninterrupted transmitting can be secured. Following information should be noted:

- Not near electrical wiring, strong magnetic fields or devices such as PC's, TV's, microwaves, etc.
- Not near big steel structures or building materials containing wire netting such as safety glass or concrete.
- Distance to receiver not more than 30 m or 2 floors



**OUTDOOR SENSOR AVS13.399.201 WIRELESS** The kit contains an outdoor sensor QAC34 and a wireless transmitter AVS13. The kit can be used in combination with a wireless receiver AVS71 to enable wireless communication between the outdoor sensor and the boiler.



**ROOM CONTROLLER QAA75.610/101** The kit contains a QAA75 room unit, which communicates with the boiler via BUS communication. For each heating zone a QAA75 can be connected.

**ROOM CONTROLLER QAA78.610/301 WIRELESS** The kit contains a QAA78 wireless room unit, which communicates with the boiler via wireless BUS communication. For each heating zone a QAA78 can be connected.



**Cascade kit MASTER** The kit includes an OCI345 communication module and header sensor (incl. pocket).

**Cascade kit SLAVE** The kit includes an OCI345 communication module for the connection of slave boilers.

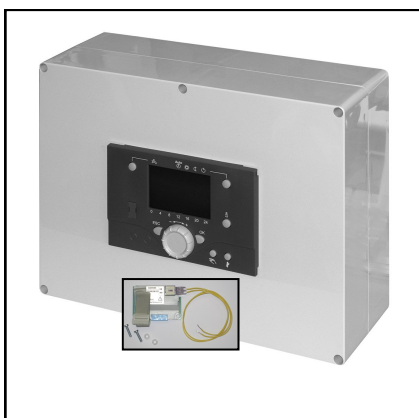

**RVS63.283/360 CONTROLLER + WALL HUNG BOX** For control of additional 2 heating zones it's possible to connect a LOGON B controller with wall hung box. The LOGON B enables the control of 2 heating zones and the control of a DHW recirculation pump. The kit includes a LOGON B controller, incl. wall hung box and communication cable.

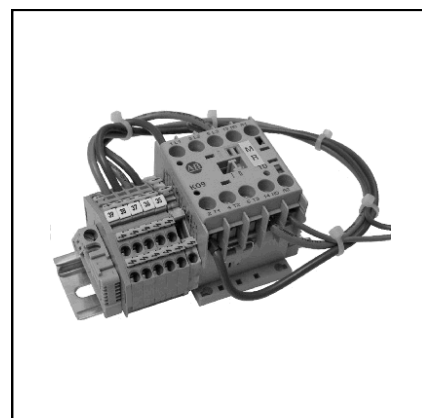

**Wiring for room fan and external gas valve** The kit contains a terminal block including wiring. When using this functionality in combination with an OK/alarm signal, an additional AVS75 extension module is necessary.

# Accessories

## Controls



### HEADER/HOT WATER SENSOR QAZ36 CABLE 6M

The kit contains a header/hot water sensor QAZ36 with 6m cable and a 1/2" pocket.



### Heating zone sensor QAD36

The kit contains a clamp sensor QAD36 with 4m cable.



### OUTDOOR SENSOR QAC34.101

The kit contains an outdoor sensor QAC34.



### Extension module AVS75.390/101 TR-XXL

The kit contains an **AVS75** extension module incl. communication cable to the LMS14 boiler management unit. Maximum 3 **AVS75** modules can be connected to one boiler (module 1 and 2 for heating zone control, module 3 for other functions).

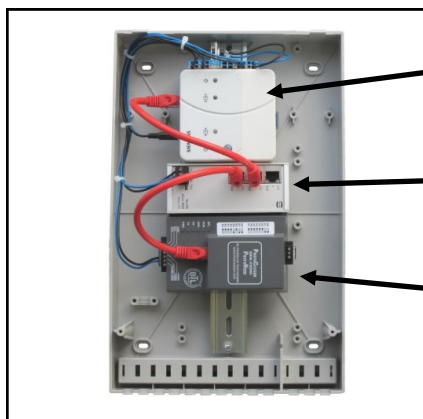

**OZW672 WEB server**  
(to convert the boiler bus system to TCP/IP protocol)

**Switch**  
(to make the connection on TCP/IP)

**Gateway ProtoNode**  
(to make the communication with the BMS)

### Commercial Gateway

The kit contains an interface to connect the boiler to a BMS.

There are 4 kits:

- 1 boiler via KNX BACnet Modbus;
- max 4 boilers via KNX BACnet Modbus;
- 1 boiler via LON;
- max 4 boilers via LON.

# Accessories

## Other



**Gas filter**  
The kit contains a gas filter which can be connected directly to the gas pipe of the boiler.



**Gas pressure regulator 100mbar + connection kit**  
The kit contains a gas pressure regulator which can be connected directly to the gas pipe of the boiler.

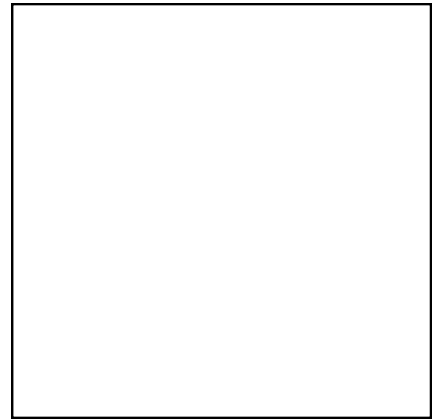

**Air filter**  
The kit contains an air filter which can be connected directly to the air intake connection of the boiler.



**Disassembly Set**  
The kit contains all gaskets which have to be replaced when dis- and reassembling a boiler.

# Accessories

## Standard pumps

### Standard pumps

Boiler	Water connection	Water flow	Hydraulic resistance	Description
		m <sup>3</sup> /h	kPa	
SE-650	DN65 PN16	28,0	46,0	TP65/120
SE-750		31,1	53,0	TP80/120
SE-850	DN80 PN16	36,4	36,0	TP80/120
SE-1000		41,2	43,0	TP80/120
SE-1100		46,0	50,0	TP80/120
SE-1200		50,8	58,0	TP80-170/4
SE-1300		55,6	91,0	TP80-170/4
SE-1500		63,5	60,0	TP80-170/4
SE-1700		71,5	130,0	TP80-270/4
SE-1900		79,4	165,0	TP80-270/4
ECO-650		DN65 PN16	26,5	37,0
ECO-750	DN80 PN16	31,0	25,0	TP80/120
ECO-850		35,1	30,0	TP65/120
ECO-950		39,2	35,0	TP80/120
ECO-1050		43,2	40,0	TP80/120
ECO-1150		47,3	60,0	TP80-170/4
ECO-1300		54,0	72,0	TP80-170/4
ECO-1450		60,8	93,0	TP80-170/4
ECO-1600		67,5	114,0	TP80-170/4
EVO-700		DN65 PN16	27,5	74,0
EVO-800	DN80 PN16	32,2	40,0	TP80/120
EVO-900		36,4	45,0	TP80/120
EVO-1000		40,7	67,0	TP80/120
EVO-1100		44,9	78,0	TP80-90/4
EVO-1200		49,1	82,0	TP80-170/4
EVO-1400		56,2	96,0	TP80-170/4
EVO-1550		63,2	136,0	TP80-270/4
EVO-1700		70,2	162,0	TP80-270/4
EVO-2000		84,1	216,0	

# Accessories

## Speed control pumps Bypass pumps

### Speed control pumps

Boiler	Water connection	Water flow	Hydraulic resistance	Description
		m <sup>3</sup> /h	kPa	
ECO-650	DN65 PN16	26,5	37,0	MAGNA3 65-120 F
ECO-750	DN80 PN16	31,0	25,0	MAGNA3 80-120 F
ECO-850		35,1	30,0	MAGNA3 80-120 F
ECO-950		39,2	35,0	MAGNA3 80-120 F
ECO-1050		43,2	40,0	MAGNA3 80-120 F
ECO-1150		47,3	60,0	TPE2 80-180
ECO-1300		54,0	72,0	TPE2 80-180
ECO-1450		60,8	93,0	TPE 80-170/4
ECO-1600		67,5	114,0	TPE 80-170/4
EVO-700		DN65 PN16	27,5	74,0
EVO-800	DN80 PN16	32,2	40,0	MAGNA3 80-120 F
EVO-900		36,4	45,0	MAGNA3 80-120 F
EVO-1000		40,7	67,0	MAGNA3 80-120 F
EVO-1100		44,9	78,0	TPE2 80-180
EVO-1200		49,1	82,0	TPE2 80-180
EVO-1400		56,2	96,0	TPE 80-170/4
EVO-1550		63,2	136,0	TPE 80-170/4
EVO-1700		70,2	162,0	TPE 80-170/4
EVO-2000		84,1	216,0	

### Bypass pumps

Boiler	Water connection	Water flow	Hydraulic resistance	Description
		m <sup>3</sup> /h	kPa	
EVO-700	DN65 PN16	27,5	74,0	TP50-30/4
EVO-800	DN80 PN16	32,2	40,0	TP50-30/4
EVO-900		36,4	45,0	TP65-30/4
EVO-1000		40,7	67,0	TP65-30/4
EVO-1100		44,9	78,0	TP65-30/4
EVO-1200		49,1	82,0	TP65-30/4

# Accessories

## Standard pumps performance curves

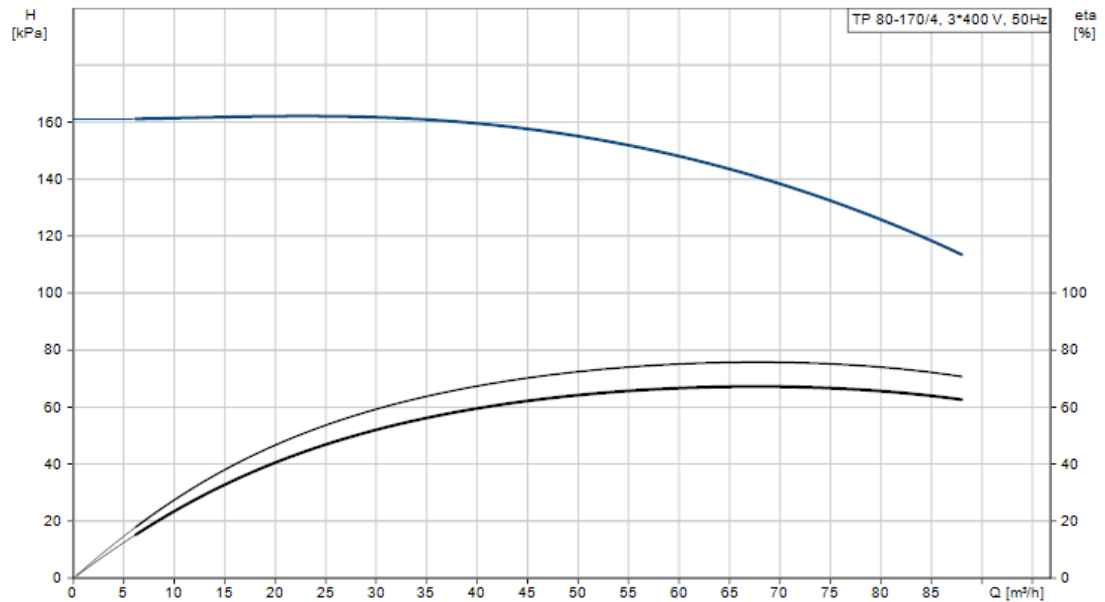
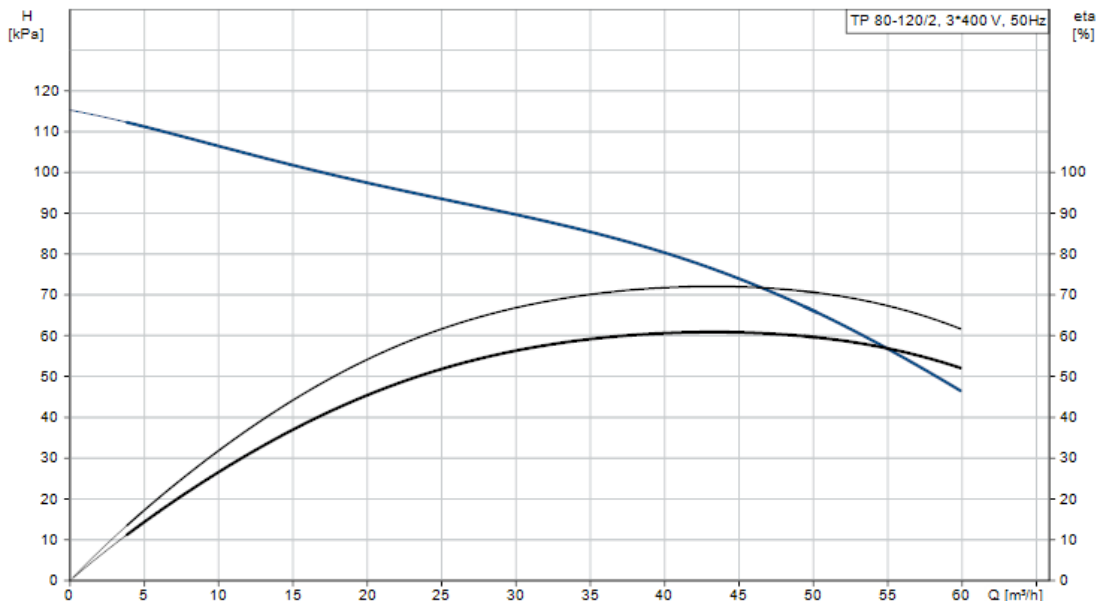
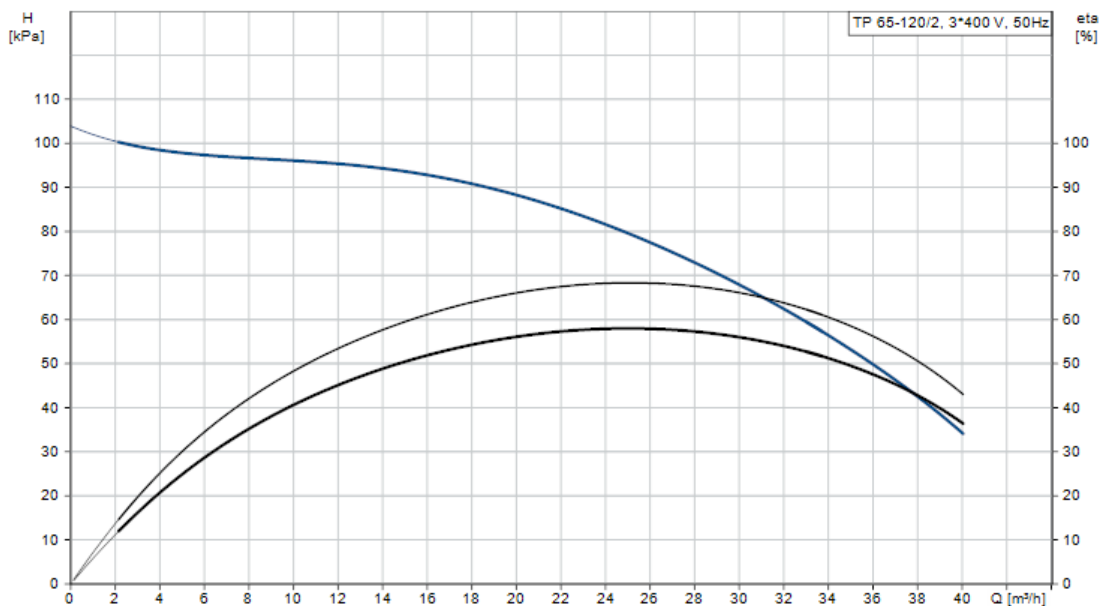

# Accessories

## Standard pumps performance curves Speed control pumps performance curves

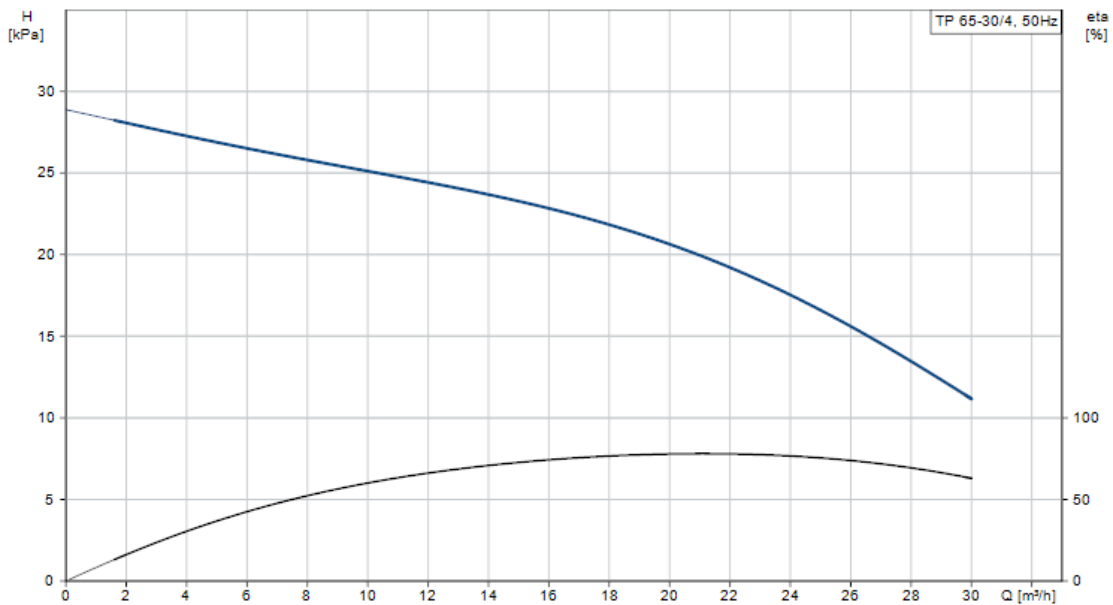
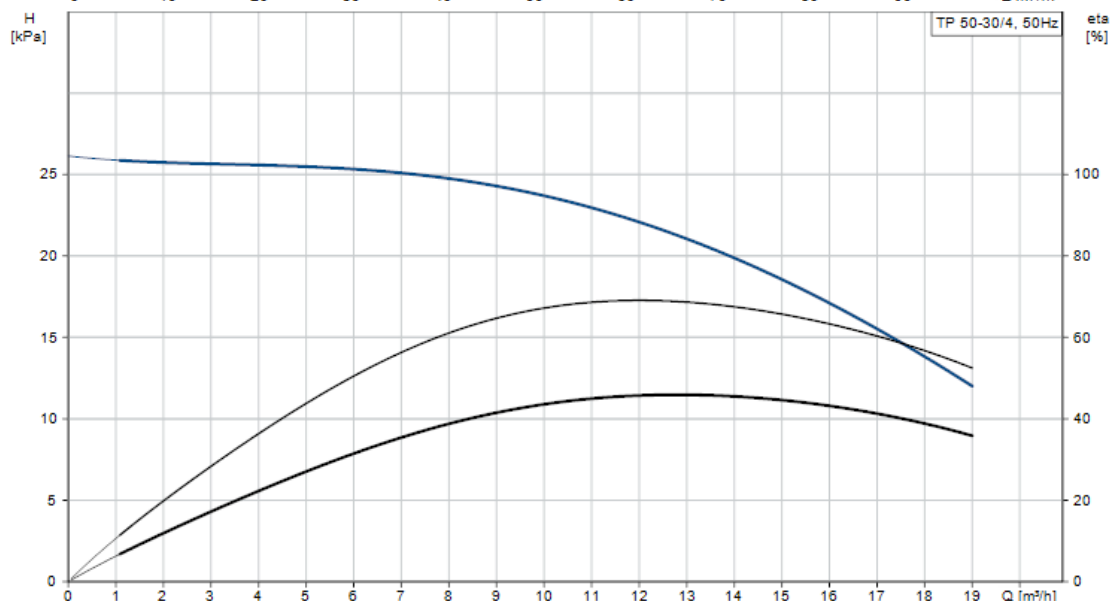
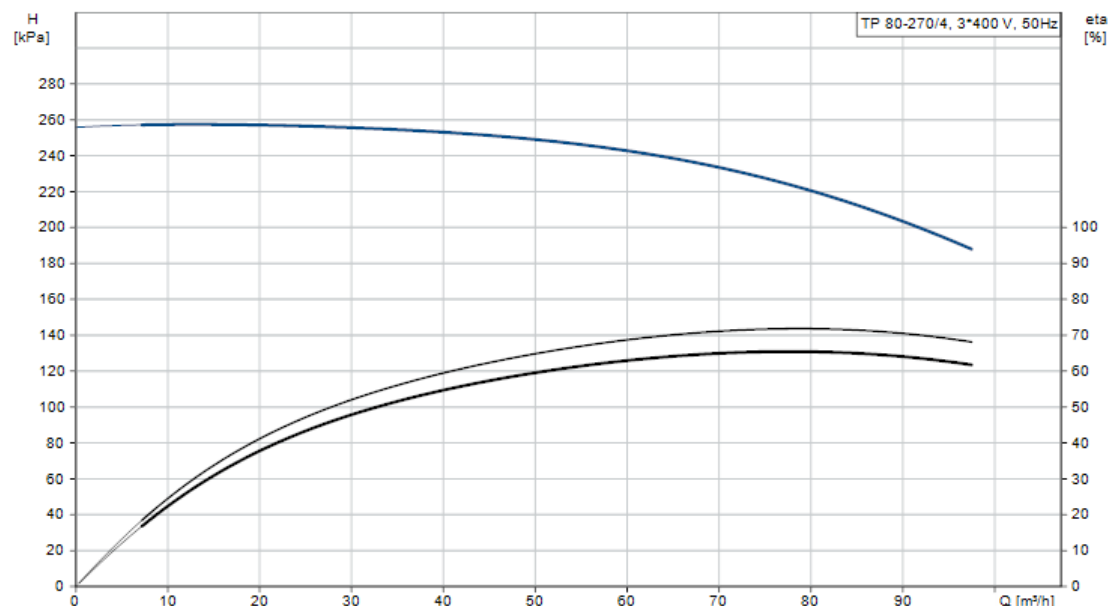

# Accessories

## Modulating pumps performance curves

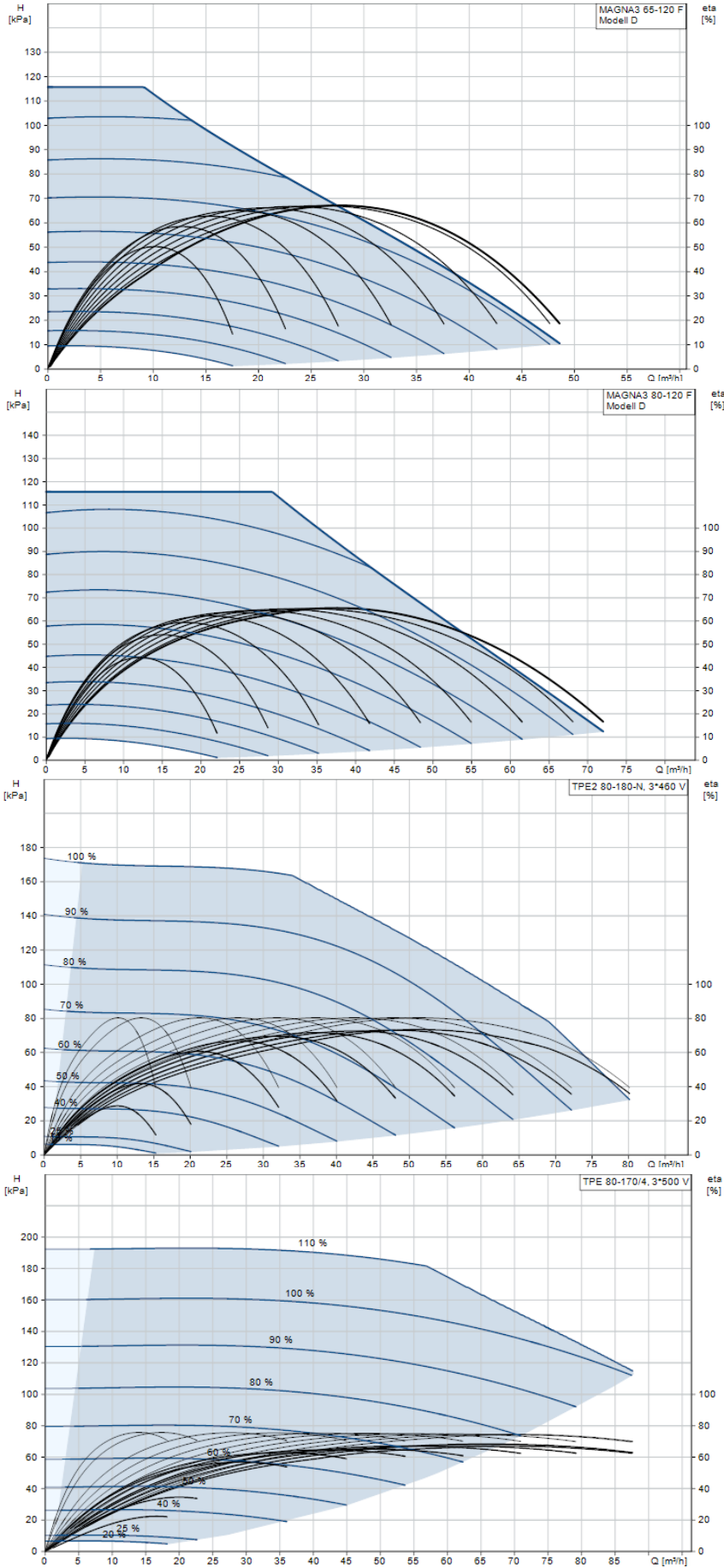

# Installation examples

## 2-A-C: 1 heating zone + low loss header

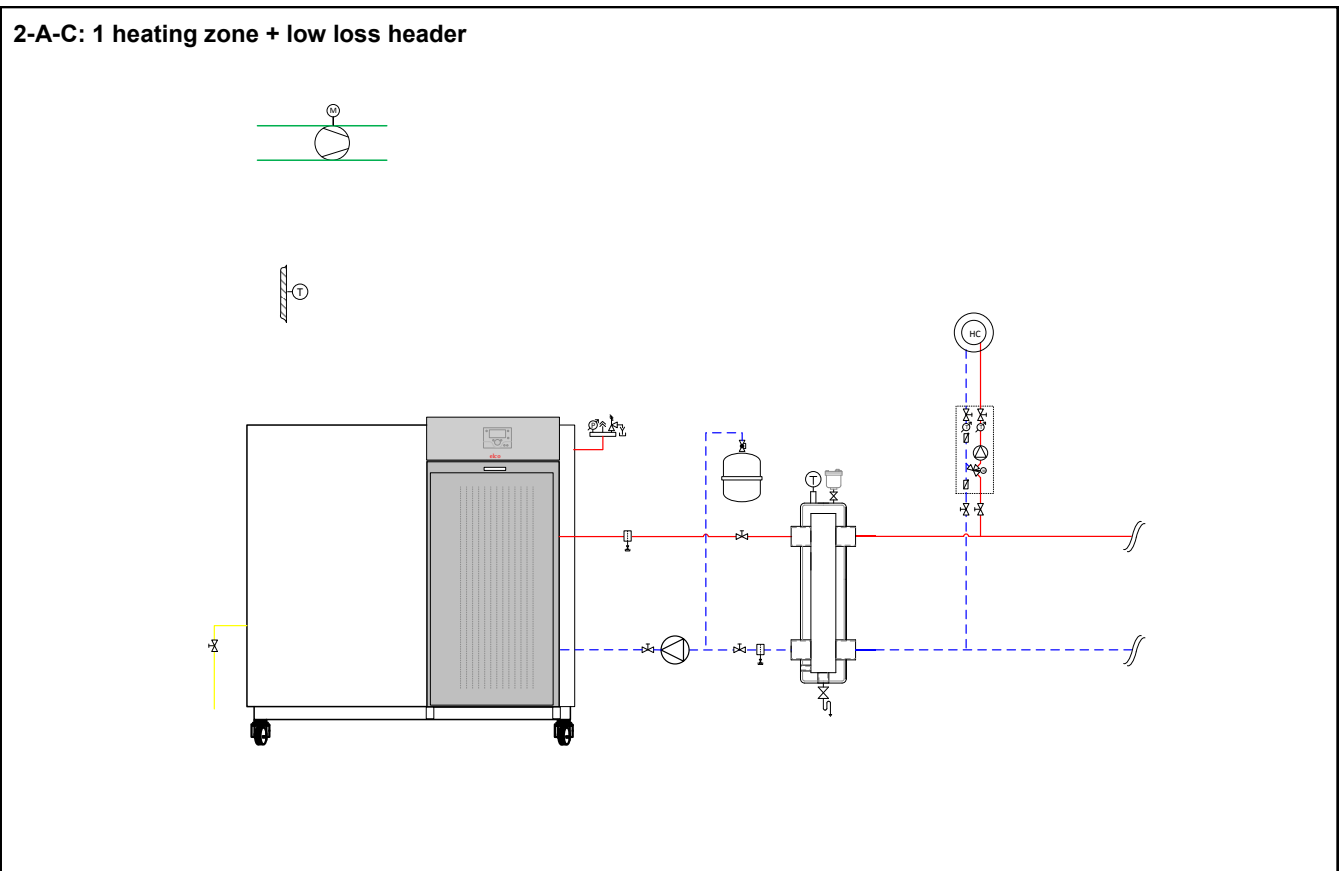

### Description

- TRIGON XXL with low loss header
- Weather compensated control
- 1 mixed heating zone

### Tips

- Complete accessory kits with low loss header are available for  $\Delta T=10-20K$  (see chapter „Accessories“).
- The primary circuit should be designed for  $\Delta T=20K$ , this guarantees a high boiler efficiency.
- When the secondary circuit is designed for a  $\Delta T$  smaller than  $20K$ , the flow temperature in the header will be lower than the flow temperature of the boiler. This should be taken in consideration during the design stage.
- The header should be positioned close to the boiler, to avoid a negative influence on the temperature control quality.
- In case of a boiler room installed on the roof, the boiler may never be hydraulically connected at the highest point of the installation.

# Installation examples

## 2-5-A-C: 1 heating zone and sanitary hot water + low loss header

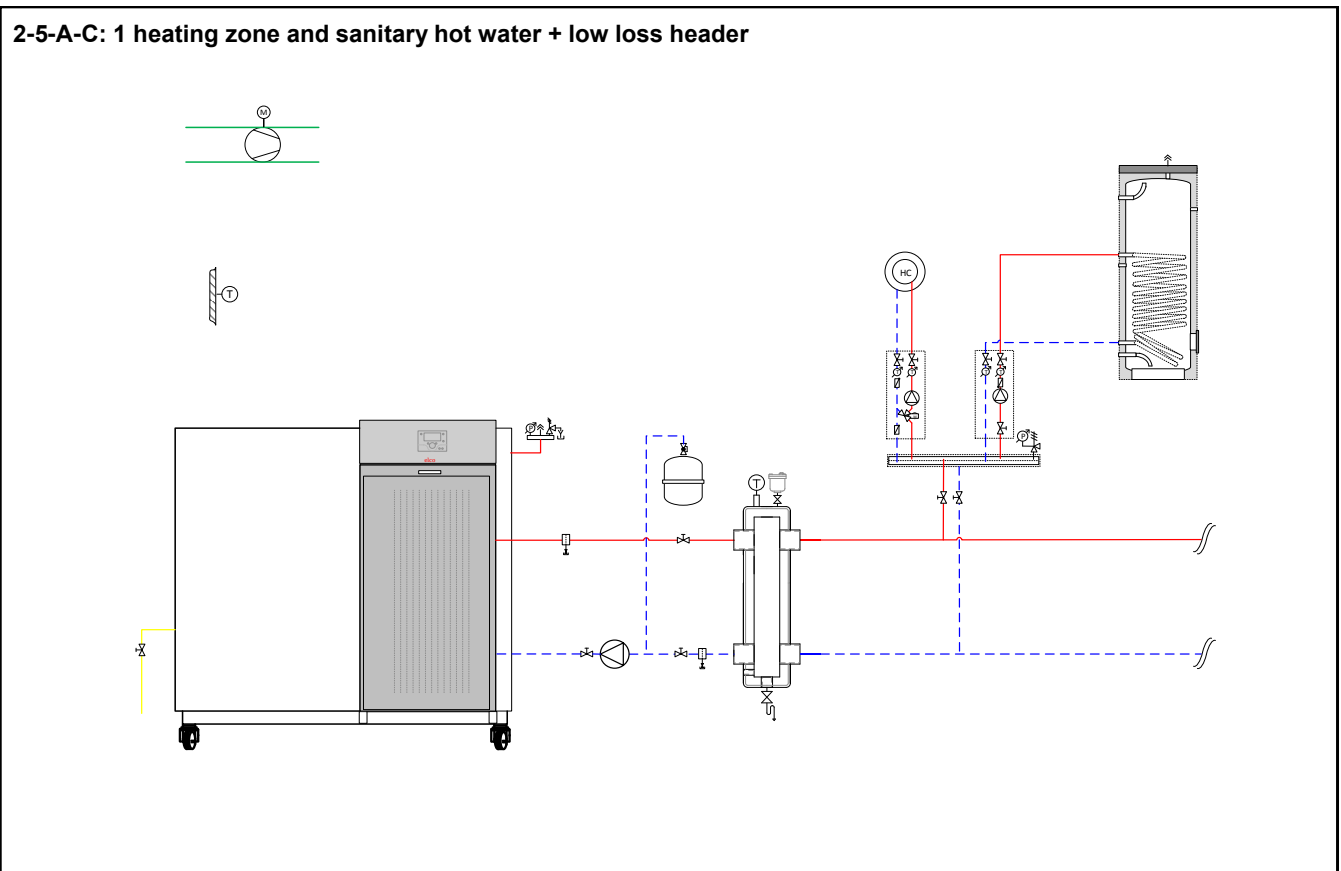

### Description

- TRIGON XXL with low loss header
- Weather compensated control
- 1 mixed heating zone
- Sanitary hot water

### Tips

- Complete accessory kits with low loss header are available for  $\Delta T=10-20K$  (see chapter „Accessories“).
- The primary circuit should be designed for  $\Delta T=20K$ , this guarantees a high boiler efficiency.
- When the secondary circuit is designed for a  $\Delta T$  smaller than  $20K$ , the flow temperature in the header will be lower than the flow temperature of the boiler. This should be taken in consideration during the design stage.
- The header should be positioned close to the boiler, to avoid a negative influence on the temperature control quality.
- In case of a boiler room installed on the roof, the boiler may never be hydraulically connected at the highest point of the installation.

# Installation examples

## 4-A-C: 2 heating zones + low loss header

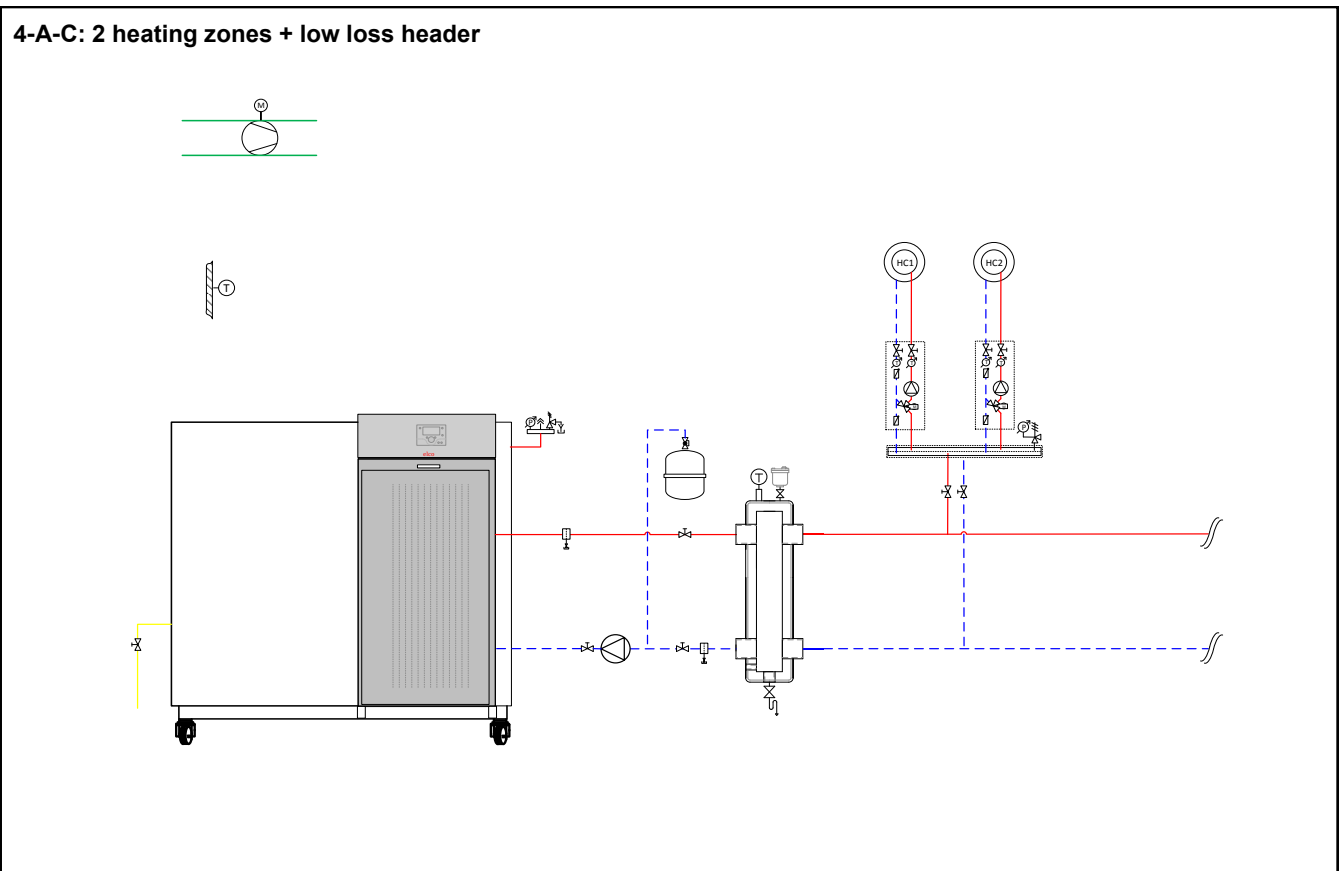

### Description

- TRIGON XXL with low loss header
- Weather compensated control
- 2 mixed heating zones

### Tips

- Complete accessory kits with low loss header are available for  $\Delta T=10-20K$  (see chapter „Accessories“).
- The primary circuit should be designed for  $\Delta T=20K$ , this guarantees a high boiler efficiency.
- When the secondary circuit is designed for a  $\Delta T$  smaller than  $20K$ , the flow temperature in the header will be lower than the flow temperature of the boiler. This should be taken in consideration during the design stage.
- The header should be positioned close to the boiler, to avoid a negative influence on the temperature control quality.
- In case of a boiler room installed on the roof, the boiler may never be hydraulically connected at the highest point of the installation.

# Installation examples

## 4-5-A-C: 2 heating zones and sanitary hot water + low loss header

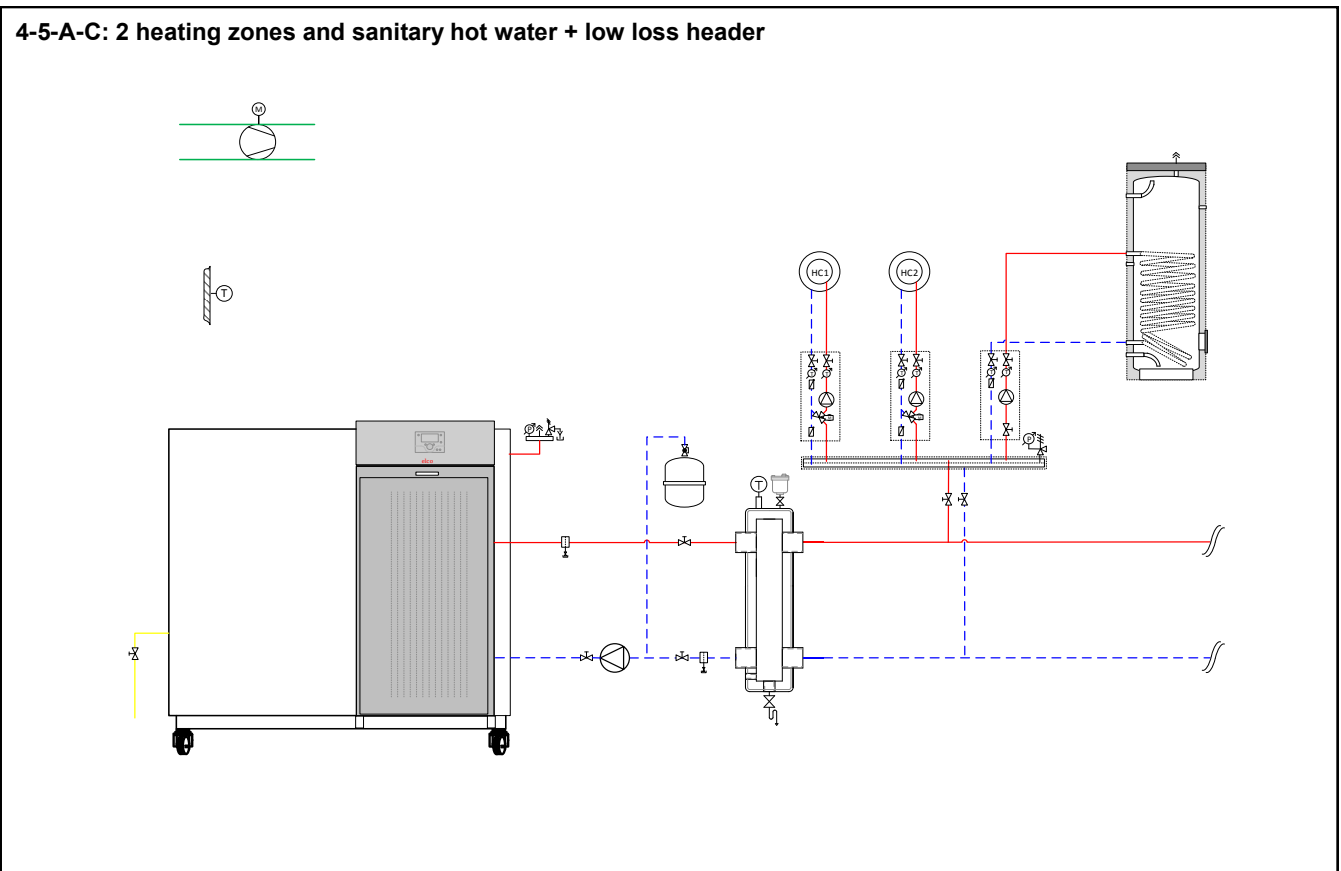

### Description

- TRIGON XXL with low loss header
- Weather compensated control
- 2 mixed heating zones
- Sanitary hot water

### Tips

- Complete accessory kits with low loss header are available for  $\Delta T=10-20K$  (see chapter „Accessories“).
- The primary circuit should be designed for  $\Delta T=20K$ , this guarantees a high boiler efficiency.
- When the secondary circuit is designed for a  $\Delta T$  smaller than 20K, the flow temperature in the header will be lower than the flow temperature of the boiler. This should be taken in consideration during the design stage.
- The header should be positioned close to the boiler, to avoid a negative influence on the temperature control quality.
- In case of a boiler room installed on the roof, the boiler may never be hydraulically connected at the highest point of the installation.

# Installation examples

## A-C: Boiler control via 0-10VDC + low loss header

### A-C: Boiler control via 0-10VDC + low loss header

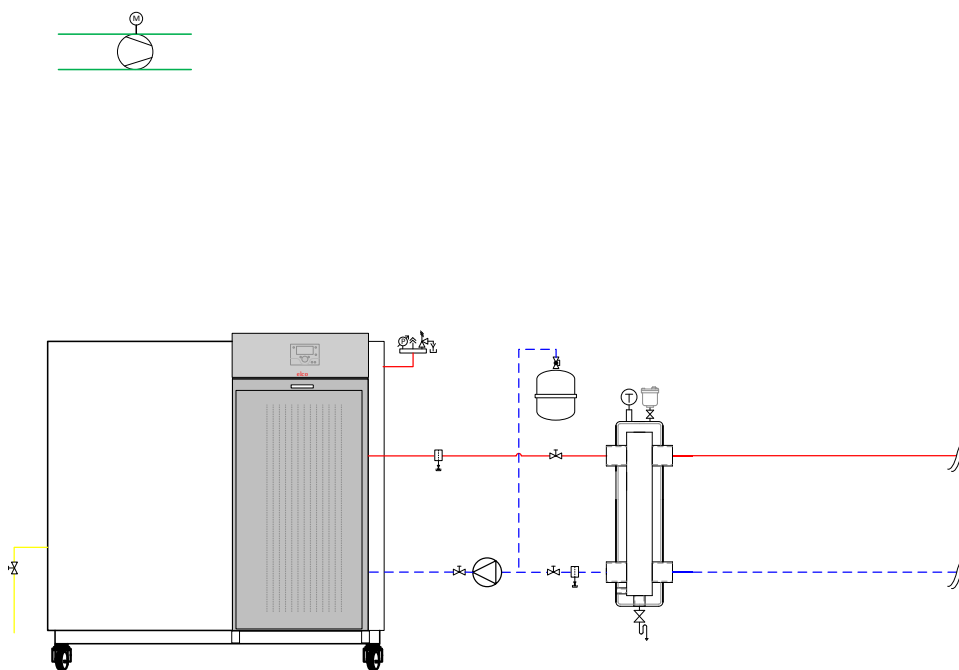

#### Description

- TRIGON XXL with low loss header

#### Tips

- Complete accessory kits with low loss header are available for  $\Delta T=10-20K$  (see chapter „Accessories“).
- The primary circuit should be designed for  $\Delta T=20K$ , this guarantees a high boiler efficiency.
- When the secondary circuit is designed for a  $\Delta T$  smaller than  $20K$ , the flow temperature in the header will be lower than the flow temperature of the boiler. This should be taken in consideration during the design stage.
- The header should be positioned close to the boiler, to avoid a negative influence on the temperature control quality.
- In case of a boiler room installed on the roof, the boiler may never be hydraulically connected at the highest point of the installation.

# Installation examples

## B-C: Boiler control via 0-10VDC + plate heat exchanger

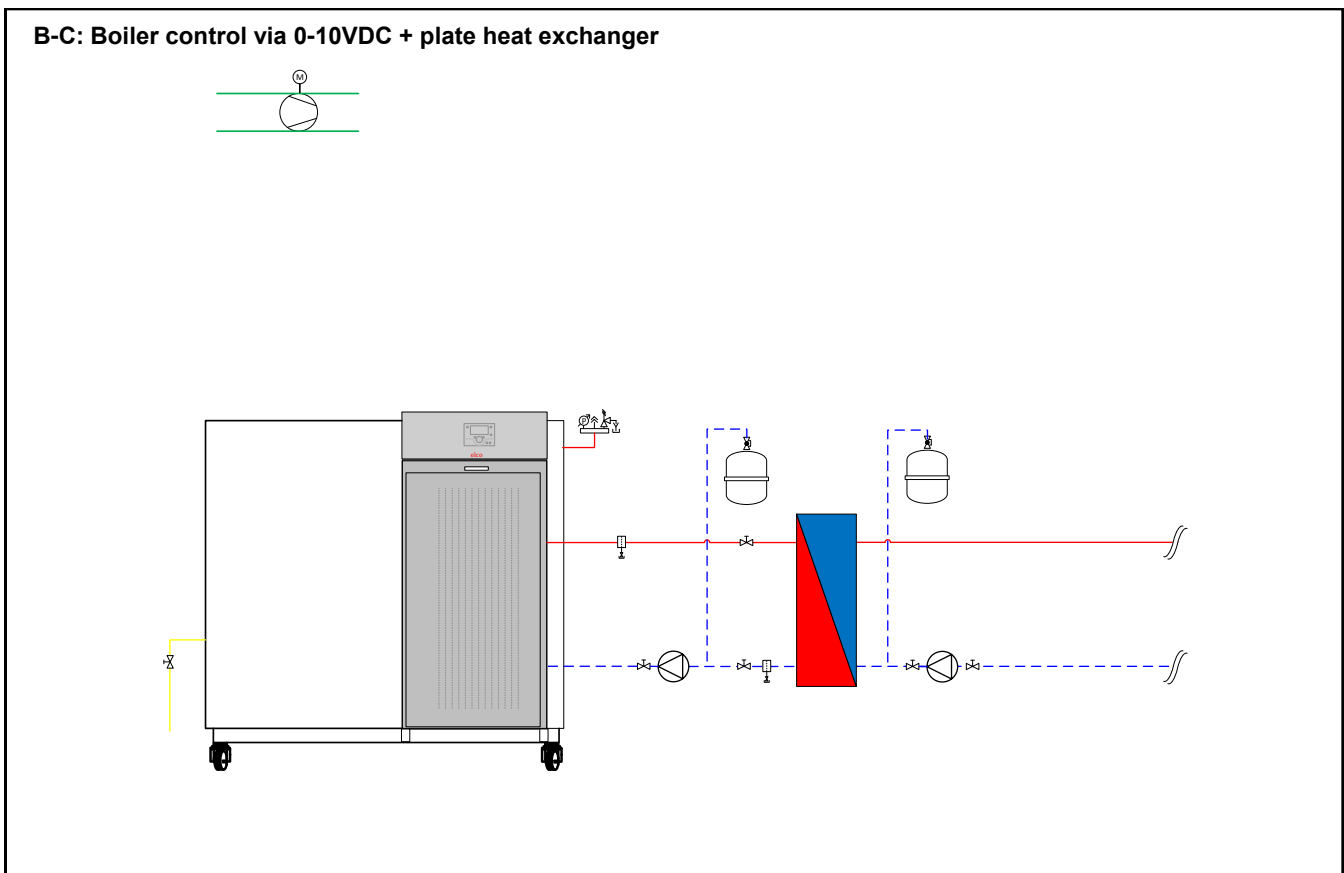

### Description

- TRIGON XXL with plate heat exchanger

### Tips

- Complete accessory kits with plate heat exchanger are available for  $\Delta T=10-20K$  (see chapter „Accessories“).
- The primary circuit should be designed for  $\Delta T=20K$ , this guarantees a high boiler efficiency.
- When the secondary circuit is designed for a  $\Delta T$  smaller than 20K, the flow temperature of the plate heat exchanger will be lower than the flow temperature of the boiler. This should be taken in consideration during the design stage.
- The plate heat exchanger should be positioned close to the boiler, to avoid a negative influence on the temperature control quality.
- In case of a boiler room installed on the roof, the boiler may never be hydraulically connected at the highest point of the installation.

# Installation examples

## 4-5-A-C-E: 2 heating zones and sanitary hot water + cascade via low loss header

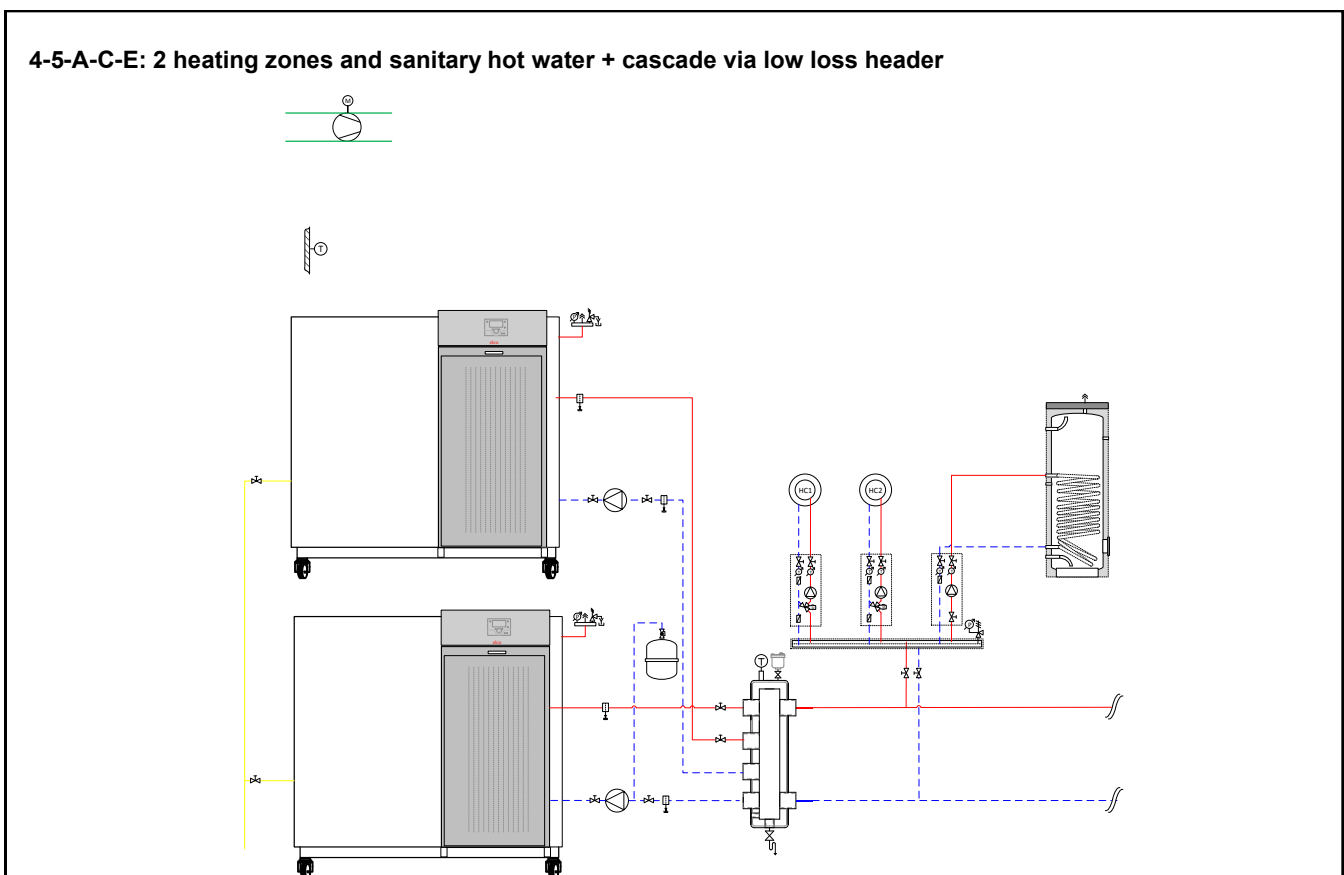

### Description

- 2x TRIGON XXL with low loss header
- Cascade control + weather compensation
- 2 mixed heating zones
- Sanitary hot water

### Tips

- Low loss duo headers are available for  $\Delta T=15-20K$  (see chapter „Accessories“).
- The primary circuit should be designed for  $\Delta T=20K$ , this guarantees a high boiler efficiency.
- When the secondary circuit is designed for a  $\Delta T$  smaller than  $20K$ , the flow temperature in the header will be lower than the flow temperature of the boiler. This should be taken in consideration during the design stage.
- The header should be positioned close to the boiler, to avoid a negative influence on the temperature control quality.
- In case of a boiler room installed on the roof, the boiler may never be hydraulically connected at the highest point of the installation.

# Installation examples

## Extension 2 heating zones

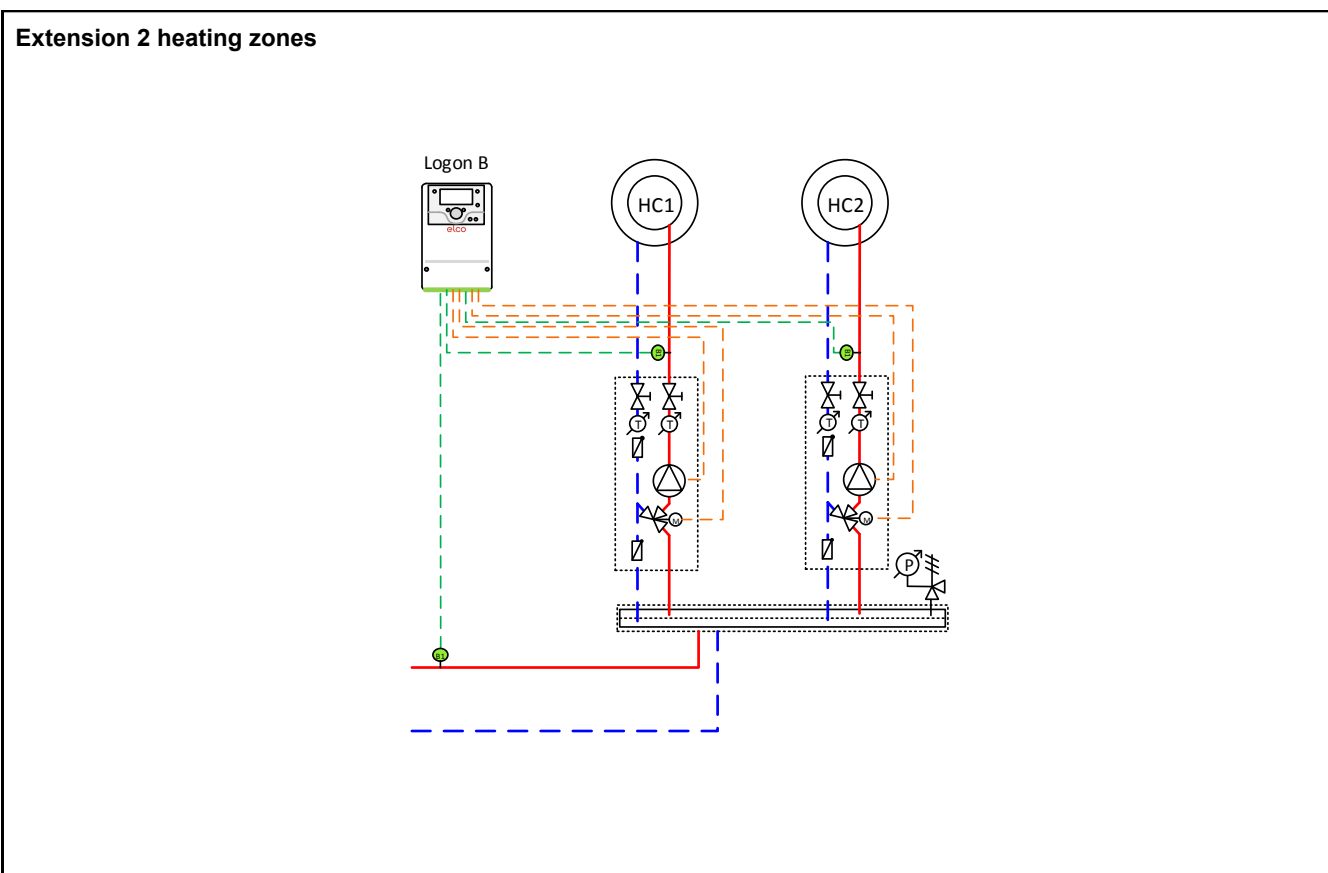

### Description

- Weather compensated controller with wall hung box LOGON B
- Extension of 2 heating zones

### Tips

- The extension controller should always be used in combination with the integrated boiler controller LMS14
- With the extension controller 2 additional heating zones can be controlled.
- The heating zone control can be extended up to 15 heating zones.

# Technical Data

## Country specific

Germany/Austria/Switzerland: EnEV (Anlagenaufwandzahl, DIN V4701-10)

		TRIGON XXL SE									
		650	750	850	1000	1100	1200	1300	1500	1700	1900
Nominal heat output at 80/60°C	kW	649,7	725,6	848,7	960,7	1072,7	1183,7	1295,7	1480,8	1665,9	1851,0
Nominal heat output at 40/30°C	kW	656,6	733,3	857,7	970,8	1084,0	1196,2	1309,4	1496,5	1683,5	1870,6
Efficiency at 80/60°C full load	%	92,6	92,6	92,6	92,6	92,6	92,6	92,6	92,6	92,6	92,6
Efficiency at 36/30°C 30% load	%	102,6	102,6	102,6	102,6	102,6	102,6	102,6	102,6	102,6	102,6
Fluegas temperature at 36/30°C 30%	°C	79	79	79	79	79	79	79	79	79	79
Standstill losses (T <sub>water</sub> = 70°C)	%	0,10	0,10	0,10	0,10	0,10	0,10	0,10	0,10	0,10	0,10
Support energy	W	1929	2355	2809	2809	2808	5437	6303	6755	10689	10652

		TRIGON XXL ECO								
		650	750	850	950	1050	1150	1300	1450	1600
Nominal heat output at 80/60°C	kW	614,6	719,1	814,1	909,2	1003,3	1097,4	1254,6	1410,9	1568,0
Nominal heat output at 40/30°C	kW	625,4	731,8	828,5	925,2	1021,0	1116,8	1276,7	1435,7	1595,7
Efficiency at 80/60°C full load	%	94,1	94,1	94,1	94,1	94,1	94,1	94,1	94,1	94,1
Efficiency at 36/30°C 30% load	%	102,9	102,9	102,9	102,9	102,9	102,9	102,9	102,9	102,9
Fluegas temperature at 36/30°C 30%	°C	64	64	64	64	64	64	64	64	64
Standstill losses (T <sub>water</sub> = 70°C)	%	0,10	0,10	0,10	0,10	0,10	0,10	0,10	0,10	0,10
Support energy	W	1317	1639	1772	1930	2110	3466	3900	5103	5946

		TRIGON XXL EVO									
		700	800	900	1000	1100	1200	1400	1550	1700	2000
Nominal heat output at 80/60°C	kW	638,9	747,5	846,3	945,1	1043,0	1140,8	1304,2	1466,6	1630,0	1953,0
Nominal heat output at 40/30°C	kW	682,3	798,3	903,8	1009,4	1113,9	1218,4	1392,9	1566,3	1740,8	2087,2
Efficiency at 80/60°C full load	%	97,8	97,8	97,8	97,8	97,8	97,8	97,8	97,8	97,8	97,7
Efficiency at 36/30°C 30% load	%	108,4	108,4	108,4	108,4	108,4	108,4	108,4	108,4	108,4	108,4
Fluegas temperature at 36/30°C 30%	°C	33	33	33	33	33	33	33	33	33	33
Standstill losses (T <sub>water</sub> = 70°C)	%	0,10	0,10	0,10	0,10	0,10	0,10	0,10	0,10	0,10	0,10
Support energy	W	1774	1466	2000	2448	2610	3881	4548	6220	7332	2770

# Technical Data

## Country specific

### Italy: Legge 10

		TRIGON XXL SE									
		650	750	850	1000	1100	1200	1300	1500	1700	1900
Combustion efficiency (indirect) at 80/60°C full load (burner on)	%	92,3	92,3	92,3	92,3	92,3	92,3	92,3	92,3	92,3	92,3
Combustion efficiency (indirect) at 80/60°C min load (burner on)	%	97,7	97,7	97,7	97,7	97,7	97,7	97,7	97,7	97,7	97,7
Combustion efficiency (indirect) at 40/30°C full load (burner on)	%	93,0	93,0	93,0	93,0	93,0	93,0	93,0	93,0	93,0	93,0
Combustion efficiency (indirect) at 40/30°C min load (burner on)	%	97,7	97,7	97,7	97,7	97,7	97,7	97,7	97,7	97,7	97,7
Combustion efficiency (direct) at 80/60°C full load	%	92,6	92,6	92,6	92,6	92,6	92,6	92,6	92,6	92,6	92,6
Combustion efficiency (direct) at 80/60°C 30% load	%	93,2	93,2	93,2	93,2	93,2	93,2	93,2	93,2	93,2	93,2
Combustion efficiency (direct) at	%	93,5	93,5	93,5	93,5	93,5	93,5	93,5	93,5	93,5	93,5
Combustion efficiency (direct) at 40/30°C 30% load	%	103,9	103,9	103,9	103,9	103,9	103,9	103,9	103,9	103,9	103,9
Thermal losses at chimney, at 80/60°C full load (burner on)	%	7,7	7,7	7,7	7,7	7,7	7,7	7,7	7,7	7,7	7,7
Thermal losses at chimney, at 80/60°C min load (burner on)	%	2,3	2,3	2,3	2,3	2,3	2,3	2,3	2,3	2,3	2,3
Thermal losses at chimney, at 40/30°C full load (burner on)	%	7,0	7,0	7,0	7,0	7,0	7,0	7,0	7,0	7,0	7,0
Thermal losses at chimney, at 40/30°C min load (burner on)	%	2,3	2,3	2,3	2,3	2,3	2,3	2,3	2,3	2,3	2,3
Thermal losses at chimney (burner	%	<0,10	<0,10	<0,10	<0,10	<0,10	<0,10	<0,10	<0,10	<0,10	<0,10
Loss on surface (casing)	%	0,10	0,10	0,10	0,10	0,10	0,10	0,10	0,10	0,10	0,10
Nett flue gas temperature at 80/60°C full load	°C	162,0	162,0	162,0	162,0	162,0	162,0	162,0	162,0	162,0	162,0
CO <sub>2</sub> level gas G20/G25 max	%	10,0	10,0	10,0	10,0	10,0	10,0	10,0	10,0	10,0	10,0

# Technical Data

## Country specific

### Italy: Legge 10

		TRIGON XXL ECO								
		650	750	850	950	1050	1150	1300	1450	1600
Combustion efficiency (indirect) at 80/60°C full load (burner on)	%	93,7	93,7	93,7	93,7	93,7	93,7	93,7	93,7	93,7
Combustion efficiency (indirect) at 80/60°C min load (burner on)	%	97,7	97,7	97,7	97,7	97,7	97,7	97,7	97,7	97,7
Combustion efficiency (indirect) at 40/30°C full load (burner on)	%	94,6	94,6	94,6	94,6	94,6	94,6	94,6	94,6	94,6
Combustion efficiency (indirect) at 40/30°C min load (burner on)	%	97,8	97,8	97,8	97,8	97,8	97,8	97,8	97,8	97,8
Combustion efficiency (direct) at 80/60°C full load	%	94,1	94,1	94,1	94,1	94,1	94,1	94,1	94,1	94,1
Combustion efficiency (direct) at 80/60°C 30% load	%	93,4	93,4	93,4	93,4	93,4	93,4	93,4	93,4	93,4
Combustion efficiency (direct) at 40/30°C full load	%	95,8	95,8	95,8	95,8	95,8	95,8	95,8	95,8	95,8
Combustion efficiency (direct) at 40/30°C 30% load	%	104,1	104,1	104,1	104,1	104,1	104,1	104,1	104,1	104,1
Thermal losses at chimney, at 80/60°C full load (burner on)	%	6,3	6,3	6,3	6,3	6,3	6,3	6,3	6,3	6,3
Thermal losses at chimney, at 80/60°C min load (burner on)	%	2,3	2,3	2,3	2,3	2,3	2,3	2,3	2,3	2,3
Thermal losses at chimney, at 40/30°C full load (burner on)	%	5,4	5,4	5,4	5,4	5,4	5,4	5,4	5,4	5,4
Thermal losses at chimney, at 40/30°C min load (burner on)	%	2,2	2,2	2,2	2,2	2,2	2,2	2,2	2,2	2,2
Thermal losses at chimney (burner off)	%	<0,10	<0,10	<0,10	<0,10	<0,10	<0,10	<0,10	<0,10	<0,10
Loss on surface (casing)	%	0,10	0,10	0,10	0,10	0,10	0,10	0,10	0,10	0,10
Nett flue gas temperature at 80/60°C full load	°C	133,0	133,0	133,0	133,0	133,0	133,0	133,0	133,0	133,0
CO <sub>2</sub> level gas G20/G25 max	%	10,0	10,0	10,0	10,0	10,0	10,0	10,0	10,0	10,0

# Technical Data

## Country specific

### Italy: Legge 10

		TRIGON XXL EVO										
		700	800	900	1000	1100	1200	1400	1550	1700	2000	
Combustion efficiency (indirect) at 80/60°C full load (burner on)	%	97,7	97,7	97,7	97,7	97,7	97,7	97,7	97,7	97,7	97,7	97,5
Combustion efficiency (indirect) at 80/60°C min load (burner on)	%	98,0	98,0	98,0	98,0	98,0	98,0	98,0	98,0	98,0	98,0	98,0
Combustion efficiency (indirect) at 40/30°C full load (burner on)	%	98,5	98,5	98,5	98,5	98,5	98,5	98,5	98,5	98,5	98,5	98,5
Combustion efficiency (indirect) at 40/30°C min load (burner on)	%	99,4	99,4	99,4	99,4	99,4	99,4	99,4	99,4	99,4	99,4	99,4
Combustion efficiency (direct) at 80/60°C full load	%	97,8	97,8	97,8	97,8	97,8	97,8	97,8	97,8	97,8	97,8	97,7
Combustion efficiency (direct) at 80/60°C 30% load	%	97,4	97,4	97,4	97,4	97,4	97,4	97,4	97,4	97,4	97,4	97,4
Combustion efficiency (direct) at	%	104,5	104,5	104,5	104,5	104,5	104,5	104,5	104,5	104,5	104,5	104,4
Combustion efficiency (direct) at 40/30°C 30% load	%	109,7	109,7	109,7	109,7	109,7	109,7	109,7	109,7	109,7	109,7	109,7
Thermal losses at chimney, at 80/60°C full load (burner on)	%	2,3	2,3	2,3	2,3	2,3	2,3	2,3	2,3	2,3	2,3	2,5
Thermal losses at chimney, at 80/60°C min load (burner on)	%	2,0	2,0	2,0	2,0	2,0	2,0	2,0	2,0	2,0	2,0	2,0
Thermal losses at chimney, at 40/30°C full load (burner on)	%	1,5	1,5	1,5	1,5	1,5	1,5	1,5	1,5	1,5	1,5	1,5
Thermal losses at chimney, at 40/30°C min load (burner on)	%	0,6	0,6	0,6	0,6	0,6	0,6	0,6	0,6	0,6	0,6	0,6
Thermal losses at chimney (burner	%	<0,10	<0,10	<0,10	<0,10	<0,10	<0,10	<0,10	<0,10	<0,10	<0,10	<0,10
Loss on surface (casing)	%	0,10	0,10	0,10	0,10	0,10	0,10	0,10	0,10	0,10	0,10	0,10
Nett flue gas temperature at 80/60°C full load	°C	49,0	49,0	49,0	49,0	49,0	49,0	49,0	49,0	49,0	49,0	53,4
CO <sub>2</sub> level gas G20/G25 max	%	10,0	10,0	10,0	10,0	10,0	10,0	10,0	10,0	10,0	10,0	10,0

# Technical Data

## Country specific

### RT2012 (France only)

		TRIGON XXL SE									
		650	750	850	1000	1100	1200	1300	1500	1700	1900
Nominal heat output at 80-60°C	kW	649,7	725,6	848,7	960,7	1072,7	1183,7	1295,7	1480,8	1665,9	1851,0
Minimal heat output at 80-60°C	kW	164,0	182,7	213,4	242,3	270,3	298,2	326,2	372,8	419,4	466,0
Efficiency at 80/60°C full load	%	92,6	92,6	92,6	92,6	92,6	92,6	92,6	92,6	92,6	92,6
Efficiency at 36/30°C 30% load	%	102,6	102,6	102,6	102,6	102,6	102,6	102,6	102,6	102,6	102,6
Standstill losses (dT=30K ; T <sub>water</sub> = 50°C; T <sub>amb</sub> = 20°C)	W	n.a.	n.a.	n.a.	n.a.	n.a.	n.a.	n.a.	n.a.	n.a.	n.a.
Loss on surface (casing)	%	0,10	0,10	0,10	0,10	0,10	0,10	0,10	0,10	0,10	0,10
Power consumption boiler max	W	900,0	900,0	1270,0	1270,0	1270,0	1270,0	2334,0	2334,0	2770,0	2770,0
Power consumption boiler min (excl. pump)	W	225,0	225,0	320,0	320,0	320,0	320,0	585,0	585,0	695,0	695,0
Power consumption boiler at	W	14	14	14	14	14	14	14	14	14	14
Power consumption max pump	W	1029	1455	1539	1539	1538	4167	3969	4421	7919	7882
Operating temperature boiler max	°C	100	100	100	100	100	100	100	100	100	100
Operating temperature boiler min	°C	5	5	5	5	5	5	5	5	5	5
Nominal water flow at dT=20K	m <sup>3</sup> /h	27,9	31,2	36,5	41,3	46,1	50,9	55,7	63,7	71,6	79,6

		TRIGON XXL ECO								
		650	750	850	950	1050	1150	1300	1450	1600
Nominal heat output at 80-60°C	kW	614,6	719,1	814,1	909,2	1003,3	1097,4	1254,6	1410,9	1568,0
Minimal heat output at 80-60°C	kW	174,7	203,6	230,7	257,8	284,9	311,0	355,9	399,8	444,6
Efficiency at 80/60°C full load	%	94,1	94,1	94,1	94,1	94,1	94,1	94,1	94,1	94,1
Efficiency at 36/30°C 30% load	%	102,9	102,9	102,9	102,9	102,9	102,9	102,9	102,9	102,9
Standstill losses (dT=30K ; T <sub>water</sub> = 50°C; T <sub>amb</sub> = 20°C)	W	n.a.	n.a.	n.a.	n.a.	n.a.	n.a.	n.a.	n.a.	n.a.
Loss on surface (casing)	%	0,10	0,10	0,10	0,10	0,10	0,10	0,10	0,10	0,10
Power consumption boiler max (excl. pump)	W	900,0	1270,0	1270,0	1270,0	1270,0	2334,0	2334,0	2770,0	2770,0
Power consumption boiler min (excl. pump)	W	225,0	320,0	320,0	320,0	320,0	585,0	585,0	695,0	695,0
Power consumption boiler at standstill (no load)	W	14	14	14	14	14	14	14	14	14
Power consumption max pump	W	417	369	502	660	840	1132	1566	2333	3176
Operating temperature boiler max	°C	100	100	100	100	100	100	100	100	100
Operating temperature boiler min	°C	5	5	5	5	5	5	5	5	5
Nominal water flow at dT=20K	m <sup>3</sup> /h	26,4	30,9	35,0	39,1	43,1	47,2	53,9	60,7	67,4

# Technical Data

## Country specific

### RT2012 (France only)

		TRIGON XXL EVO									
		700	800	900	1000	1100	1200	1400	1550	1700	2000
Nominal heat output at 80-60°C	kW	638,9	747,5	846,3	945,1	1043,0	1140,8	1304,2	1466,6	1630,0	1953,0
Minimal heat output at 80-60°C	kW	182,1	212,3	240,6	268,8	297,1	324,3	371,1	416,9	463,6	487,0
Efficiency at 80/60°C full load	%	97,8	97,8	97,8	97,8	97,8	97,8	97,8	97,8	97,8	97,7
Efficiency at 36/30°C 30% load	%	108,4	108,4	108,4	108,4	108,4	108,4	108,4	108,4	108,4	108,4
Standstill losses (dT=30K ; T <sub>water</sub> = 50°C; T <sub>amb</sub> = 20°C)	W	n.a.	n.a.	n.a.	n.a.	n.a.	n.a.	n.a.	n.a.	n.a.	n.a.
Loss on surface (casing)	%	0,10	0,10	0,10	0,10	0,10	0,10	0,10	0,10	0,10	0,10
Power consumption boiler max	W	900,0	1270,0	1270,0	1270,0	1270,0	2334,0	2334,0	2770,0	2770,0	2770,0
Power consumption boiler min (excl. pump)	W	225,0	320,0	320,0	320,0	320,0	585,0	585,0	695,0	695,0	695,0
Power consumption boiler at	W	14	14	14	14	14	14	14	14	14	14
Power consumption max pump	W	874	566	730	1178	1340	1551	2218	3450	4562	0
Operating temperature boiler max	°C	100	100	100	100	100	100	100	100	100	100
Operating temperature boiler min	°C	5	5	5	5	5	5	5	5	5	5
Nominal water flow at dT=20K	m <sup>3</sup> /h	27,5	32,1	36,4	40,6	44,8	49,0	56,1	63,1	70,1	84,0

# Technical Data

## Country specific

### UK specific data

		TRIGON XXL SE									
		650	750	850	1000	1100	1200	1300	1500	1700	1900
Efficiency at 80/60°C full load Gross	kW	83,4	83,4	83,4	83,4	83,4	83,4	83,4	83,4	83,4	83,4
Efficiency at 50/30°C min load Gross	kW	92,4	92,4	92,4	92,4	92,4	92,4	92,4	92,4	92,4	92,4
Efficiency at 40/30°C min load Gross	%	93,6	93,6	93,6	93,6	93,6	93,6	93,6	93,6	93,6	93,6
Gross seasonal efficiency	%	91,6	91,6	91,6	91,6	91,6	91,6	91,6	91,6	91,6	91,6
NOx level Gross	W	40	40	40	40	40	40	40	40	40	40
BREEAM credits 2014 UK	%	3	3	3	3	3	3	3	3	3	3
BREEAM credits 2018 UK	W	0	0	0	0	0	0	0	0	0	0
Nominal water flow at dT=10K	W	56,0	62,0	72,0	82,0	92,0	102,0	112,0	128,0	144,0	160,0
Hydraulic resistance at water flow dT=10K	W	184	212	144	172	200	232	364	240	520	660
Nominal water flow at dT=25K	W	22,4	24,8	28,8	32,8	36,8	40,8	44,8	51,2	57,6	64,0
Hydraulic resistance at water flow dT=25K	°C	29	34	23	28	32	37	58	38	83	106
Nominal water flow at dT=30K	°C	18,7	20,7	24,0	27,3	30,7	34,0	37,3	42,7	48,0	53,3
Hydraulic resistance at water flow dT=30K	m <sup>3</sup> /h	21	24	16	19	22	26	40	27	58	73

		TRIGON XXL ECO								
		650	750	850	950	1050	1150	1300	1450	1600
Efficiency at 80/60°C full load Gross	kW	84,8	84,8	84,8	84,8	84,8	84,8	84,8	84,8	84,8
Efficiency at 50/30°C min load	kW	92,7	92,7	92,7	92,7	92,7	92,7	92,7	92,7	92,7
Efficiency at 40/30°C min load	%	93,8	93,8	93,8	93,8	93,8	93,8	93,8	93,8	93,8
Gross seasonal efficiency	%	92,1	92,1	92,1	92,1	92,1	92,1	92,1	92,1	92,1
NOx level Gross	W	33	33	33	33	33	33	33	33	33
BREEAM credits 2014 UK	%	3	3	3	3	3	3	3	3	3
BREEAM credits 2018 UK	W	0	0	0	0	0	0	0	0	0
Nominal water flow at dT=10K	W	52,0	62,0	70,0	78,0	86,0	94,0	108,0	122,0	134,0
Hydraulic resistance at water flow dT=10K	W	148	100	120	140	160	240	288	372	456
Nominal water flow at dT=25K	W	20,8	24,8	28,0	31,2	34,4	37,6	43,2	48,8	53,6
Hydraulic resistance at water flow dT=25K	°C	24	16	19	22	26	38	46	60	73
Nominal water flow at dT=30K	°C	17,3	20,7	23,3	26,0	28,7	31,3	36,0	40,7	44,7
Hydraulic resistance at water flow dT=30K	m <sup>3</sup> /h	16	11	13	16	18	27	32	41	51

# Technical Data

## Country specific

### UK specific data

		TRIGON XXL EVO										
		700	800	900	1000	1100	1200	1400	1550	1700	2000	
Efficiency at 80/60°C full load Gross	kW	88,1	88,1	88,1	88,1	88,1	88,1	88,1	88,1	88,1	88,1	88,0
Efficiency at 50/30°C min load	kW	97,4	97,4	97,4	97,4	97,4	97,4	97,4	97,4	97,4	97,4	97,4
Efficiency at 40/30°C min load	%	98,8	98,8	98,8	98,8	98,8	98,8	98,8	98,8	98,8	98,8	98,8
Gross seasonal efficiency	%	96,8	96,8	96,8	96,8	96,8	96,8	96,8	96,8	96,8	96,8	96,7
NOx level Gross	W	33	33	33	33	33	33	33	33	33	33	29
BREEAM credits 2014 UK	%	3	3	3	3	3	3	3	3	3	3	3
BREEAM credits 2018 UK	W	0	0	0	0	0	0	0	0	0	0	0
Nominal water flow at dT=10K	W	54,0	64,0	72,0	82,0	90,0	98,0	112,0	126,0	140,0	168,0	
Hydraulic resistance at water flow dT=10K	W	296	160	180	268	312	328	384	544	648	864	
Nominal water flow at dT=25K	W	21,6	25,6	28,8	32,8	36,0	39,2	44,8	50,4	56,0	67,2	
Hydraulic resistance at water flow dT=25K	°C	47	26	29	43	50	52	61	87	104	138	
Nominal water flow at dT=30K	°C	18,0	21,3	24,0	27,3	30,0	32,7	37,3	42,0	46,7	56,0	
Hydraulic resistance at water flow dT=30K	m <sup>3</sup> /h	33	18	20	30	35	37	43	60	72	96	

# Norms

---

## Germany:

- DIN EN 483
- DIN EN 677
- DIN EN 13384-1
- DIN EN 13384-2
- DIN EN 12828
- DIN 18160-1
- DIN 18160-5
- DIN VDE 0100
- DIN VDE 0116
- DVGW-Arbeitsblatt G260/1-2
- Feuerungsverordnung (FeuVO) des jeweiligen Bundeslandes
- Landesbauverordnung (LBO)
- Muster-Feuerungsverordnung (MuFeuVO)
- Technische Regeln für Gas-Installationen DVGW-TRGI 86/96
- VDI2035

## Netherlands:

- NEN 2757-2 (2011)
- NEN 3028 (2006)
- NEN 1010
- Bouwbesluit (2012)
- SCIOS (Scope 1)

## France:

- EN 12098-1 : regulation system optimiser

## UK:

- Gas Safety Installation & Use Regulations.
- BS 5440-1:2008
- BS 5440-2:2009
- BS 6644:2011 Inc corrigendum No1

## Austria:

- ÖNORM H 5152: Brennwert-Feuerungsanlagen, Planungshilfen
- ÖNORM M 7443: Gasgeräte mit atm.Brenner Teil 1, 3, 5, 7
- ÖNORM M7457: Gasgeräte mit mechanisch unterstütztem Vormischbrenner
- ÖNORM M 5195-1: Heizwassernorm

## ÖVGW Richtlinien:

- G1 Techn. Richtlinie für die Errichtung von Niederdruck-Gasanlagen
- G2 Techn. Richtlinie für die Errichtung von Flüssiggasanlagen
- G41 Gasbrennwert-Feuerungsstätten, Aufstellung und Anschluss
- G4 Heizraumrichtlinie

Der TRIGON XXL ist zugelassen nach Artikel 15a B-VG und gemäß Feuerungsanlagenverordnung VO (FAV 97) Die örtlichen Bauordnungen sind zu beachten.

## Switzerland:

- PROCAL
- SVGW – Gasleitsätze G1/G2
- EKAS – Form, 1942
- BAFU
- VKF
- Wasserbehandlung laut Richtlinie SWKI Nr. 97-1

## Italy:

### Sicurezza degli impianti

- Legge 5 marzo 1990 n. 46
- D.P.R. 6/12/91 n. 447
- D.M. 20/2/92
- D.M. 1 dicembre 1975
- I.S.P.E.S.L. (ex A.N.C.C.)
- Norma UNI 8065
- Norma Uni 9615

### Sicurezza imiego gas

- Norma prEN 656
- Legge 6 dicembre 1971 n.1083
- D.M. 23/11/72
- Norma UNI 7129-72
- Norma UNI-CIG 7131-72

### Risparmio energetico

- Legge 9 gennaio 1991 n.10
- D.P.R. 26-08-93 n.412
- D.P.R. n.551 del 21 dicembre 1999

### Sicurezza antincendio

- Decreto del ministero dell'interno 16 febbraio 1982
- Decreto del ministero dell'interno 12 aprile 1996
- Norma CEI EN 60079-10
- Norma CEI 64-8 (giugno 1987)

### Provvedimenti contro l'inquinamento atmosferico

- D.P.R. 24/5 1988 n.203

# elco

---

**Service:**

[www.elco.net](http://www.elco.net)